



2025



Groove  
Owner's Manual

## Contents

Introduction .....	1
Keys, Doors, and Windows .....	3
Seats and Restraints .....	20
Storage .....	41
Instruments and Controls .....	47
Lighting .....	73
Infotainment System .....	78
Climate Controls .....	86
Driving and Operating .....	108
Vehicle Care .....	128
Service and Maintenance .....	159
Technical Data .....	164
Customer Information .....	173
Reporting Safety Defects .....	177
Index .....	179

## Introduction

The vehicle is integrated with advanced technologies, safety features, environmental protection features, and increased fuel economy features.

This manual provides necessary information to help you drive your vehicle safely and effectively.

Improper operation of the vehicle may cause crashes and injury risks. Comply with the requirements in laws and regulations of the country. If these requirements are different from those in the manual, the requirements in the laws and regulations shall prevail.

Your dealer has trained technicians who can perform required service using genuine replacement parts. See your dealer if the vehicle needs maintenance or repair.

Keep this manual in the vehicle for quick reference. Leave this manual in the vehicle if it is sold.

In the manual, the Chevrolet Service Center is called dealer for short.

## Using this Manual

- The contents at the beginning of the manual and each section are used for locating specific information.
- For directional data such as front, rear, left, and right, the driving direction shall be taken as the front.
- Some functions described in the manual may not be configured for all models, and the manual may introduce some features that are not on your vehicle.
- The manual includes the latest information available at the time of printing. GM reserves the right to make changes to the product without further notice after the manual is printed. Some pictures in the manual are illustrations only for your reference.

## Danger, Warning, and Caution

Warning messages found on vehicle labels and in this manual describe hazards and what to do to avoid or reduce them.

** Danger**

Danger indicates a hazard with a high level of risk which will result in serious injury or death.

** Warning**

Warning indicates a hazard that could result in injury or death.

**Caution**

Caution indicates a hazard that could result in property or vehicle damage.

General Motors reserves the copyright of the manual.

## Keys, Doors, and Windows

### Keys and Locks

Keys .....	3
Remote Keyless Entry (RKE) System	
Operation .....	4
Door Locks .....	8
Central Locking System .....	11

### Doors

Hood .....	11
Liftgate .....	12

### Exterior Mirrors

Power Mirrors .....	13
---------------------	----

### Interior Mirrors

Interior Rearview Mirrors .....	14
---------------------------------	----

### Windows

Power Windows .....	15
Sun Visors .....	16

### Roof

Sunroof .....	16
---------------	----

## Keys and Locks

### Keys

#### Type I



#### Type II



Each new vehicle is provided with two keys.

Keep the key number plate in a safe place to prevent illegal key making.

Different models may be provided with different keys.

Do not leave the key in the vehicle.

Take the key with you when you leave the vehicle.

If the key is lost, see your dealer.

**Caution**

Do not leave the key in the vehicle. Take the key with you when you leave the vehicle.

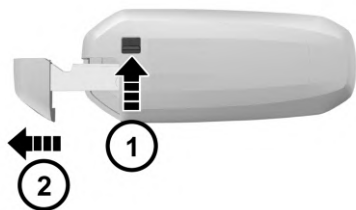
**Detachable Type**

Turn the release switch (1) on the key first, and then pull out the mechanical key (2).

Plug back the mechanical key after use.

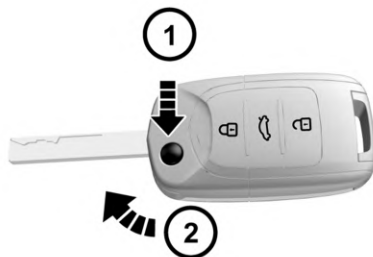
**Foldable Type**

Press the release button, and the mechanical key will pop up automatically.

Fold the mechanical key after use.

**Key-in Reminder (if equipped)**

If the driver's door is opened when the ignition key is at LOCK position and is not pulled out, the vehicle will chime. The function reminds you to take the RKE transmitter with you when you leave the vehicle.

**Remote Keyless Entry (RKE) System Operation**

The effective distance of RKE transmitter is about 15 m without shielding. When the RKE transmitter is in the ignition, or the ENGINE START STOP is at ACC or ON position, the remote control does not function.

: remote lock button. Press the button once to lock all doors. After all doors are closed; the hazard warning lamp will flash twice, and the vehicle is at anti-theft state.

: remote unlock button. Press the button once to unlock all doors; the hazard warning lamp will flash once, and the anti-theft state is released.

: liftgate unlock button. Press and hold for about two seconds; open the liftgate, and the hazard warning lamp will flash once.

The functioning range of the remote control may be different due to environmental reasons. Radio interference signals and barriers will affect the remote control functions.

### Vehicle Locating

Press the remote unlock button quickly for two times to activate the vehicle locating function, and the hazard warning lamp will flash for 20 times.

### Remote Window Lowering

Press and hold the unlock button for about two seconds to lower all windows automatically and in turn.

### Activation of Door Lock and Anti-theft Mode

1. Close all the windows.

2. Turn the ignition key to LOCK position and pull out the key (if mechanical ignition key is configured).
3. All passengers leave the vehicle.
4. Close all doors and the engine hood.
5. Press and release the remote lock button. All doors lock. The hazard warning lamp will flash twice, and the immobilizer is activated.

As for a vehicle configured with ENGINE START STOP function, only when the ignition is at LOCK position can the remote controller activate the immobilizer system.

The anti-theft mode must be activated with the transmitter.

- Warning sound

Under the anti-theft state, when the unlock button on the RKE transmitter is not pressed and any of the doors or liftgate is forced opened in an abnormal way (including use of a key), the system will make the hazard warning lamp flash and emit warning sound.

- To stop warning sound

Press and hold the lock, unlock or liftgate button on the RKE transmitter for about two seconds or turn the key to ON position to the

warning sound; if not, the warning sound will be stop automatically after 30 seconds, and the anti-theft mode is activated again. If the system fails to do so, it is recommended to have the system checked by your dealer.

### Door Unlock and Release of Anti-theft Mode

1. Press the unlock button on the RKE transmitter once.
  - All doors are unlocked.
  - The hazard warning lamp flashes once.
  - The anti-theft state is released.
2. Press and hold the liftgate open button for two seconds.
  - The liftgate is opened.
  - The hazard warning lamp flashes once.
  - The anti-theft state is released.

### Lock Function Alarm

The horn will sound three times and the hazard warning lamp will flash three times to indicate that the doors are not locked successfully if the

remote lock button is pressed or passive locking is conducted when the door lock conditions are not met. These situations include:

1. There is a door not closed (including liftgate);
2. The door lock is under thermal protection;
3. When the car is locked without the RKE transmitter, the ignition is not in LOCK position;
4. When the car is locked without a key, the Passive Entry Passive Start (PEPS) (if equipped) detects an RKE transmitter in the car.



### Warning

Never leave a child, a helpless adult, or a pet alone in a vehicle, especially with the windows closed in warm or hot weather.

They can be overcome by the extreme heat and suffer permanent injuries or even death from heat stroke.

### Automatic Locking of Door

When all doors are closed and the vehicle speed exceeds 10 km/h, all doors will be locked automatically.

### Automatic Re-locking

With the RKE transmitter not in the ignition, the vehicle will activate re-locking if the alarm is disarmed but any of the doors and liftgate is not opened within 30 seconds after the vehicle is under the armed state successfully.

### Automatic Unlocking

When the doors are locked, they will be unlocked automatically if the ignition is turned from ON position to ACC or LOCK position.

### Transmitter

Each RKE transmitter has its own electronic code to prevent the doors being opened with other RKE transmitter.

If the RKE transmitter is lost or stolen, contact your dealer to buy a new one as soon as possible. If you need to replace one or more RKE transmitters, bring the existing RKE transmitter(s) when you go to the dealer. When the dealer matches the RKE transmitter for replacement with the vehicle, the existing RKE transmitter shall also be matched with the new code. After the new RKE transmitter is coded electronically, the lost RKE transmitter will not unlock your vehicle. For Type I key, three RKE transmitters can be

configured at most each time; for Type II, four RKE transmitters can be configured at most each time.

### Signal Transmission Autostop Function of RKE Transmitter

The RKE transmitter has the signal transmission autostop function which can prevent unnecessary battery loss caused by misoperation and other reasons.

It will stop transmitting signals automatically if any button on the RKE transmitter is pressed for over 10 seconds, to save battery power of the key.

Once the button is released, the signal transmission autostop function is deactivated.

### Condition

If the RKE transmitter cannot function normally, it may be caused by the following reasons:

- Out of working range;
- Excessively low battery;
- Interference by external environment and other high-power radio signals (such as base station and launch tower);
- Signal blocking by other barriers.

### Battery Replacement

Inside the RKE transmitter, there is a lithium battery with a two-year service life. When the RKE transmitter distance is shortened gradually (i.e. must get closer to the vehicle), it indicates a low battery. The battery cannot be recharged. After the battery runs out see your dealer to have the battery changed.

To ensure normal function of the RKE transmitter:

- Avoid dropping the remote control.
- Do not place a heavy object on the remote control.
- Make sure the remote control is away from water or direct sunlight. If the remote control is soaked wipe with soft cloth.

### Passive Entry Passive Start (PEPS) System (if equipped)

If the vehicle is equipped with a PEPS system, you can lock or unlock the doors conveniently only by taking the RKE transmitter with you and getting to the certain ranges of the doors (including the liftgate). You can lock or unlock remotely without taking the RKE transmitter out of your pocket.

### Passive Entry

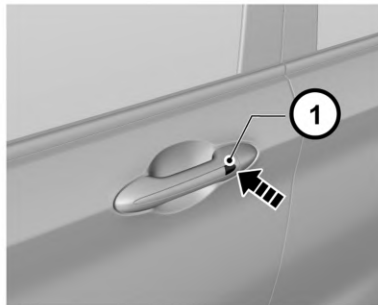

When the doors are locked, the ignition is in the LOCK position, and the RKE transmitter is within 1.2 m of the front door handle, pressing the lock/unlock button on the front door handle will unlock all the doors.

### Passive Locking

When all the doors are closed, the ignition is in the LOCK position, and the RKE transmitter is within 1.2 m of the front door handle, pressing the lock/unlock button on the front door handle will lock all the doors. The hazard warning lamp flashes twice.

The system will send warning prompt, the horn will sound three times and the hazard warning lamp will flash three times to indicate that the doors are not locked when you press the button on the door handle in case of the following situations:

- There is a door not closed;
- The ignition is not at LOCK position;
- There is a key in the vehicle.

Check one by one, and then lock again.

If the remote control battery is low, the passive entry/locking function may fail, and you can use the mechanical key to lock/unlock doors. Replace the remote control battery as soon as possible.



## Passive Unlocking/Locking of Liftgate

### Passive Unlocking

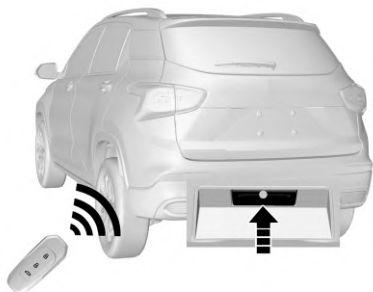

When the doors are locked, the ignition is in the LOCK position, and the RKE transmitter is within 1.2 m of the liftgate, pressing the liftgate release button will unlock the liftgate. The liftgate will open

If the doors are already unlocked, the liftgate can be opened by pressing the liftgate switch directly (unnecessary to bring the key and get close to the liftgate).

The liftgate can always be opened with the RKE transmitter.

If the doors are already unlocked, the liftgate can be opened by pressing the liftgate release switch directly

### Passive Locking

If the doors are locked when the liftgate is closed, the system will search automatically whether there is a RKE transmitter in the vehicle. If there is no RKE transmitter in the vehicle, the liftgate will be locked automatically. The hazard warning lamp flashes twice. If there is a key in the vehicle, the system will send warning prompt, the horn will sound three times and the hazard warning lamp will flash three times.

The liftgate will be locked and all four doors will be unlocked automatically. Remove the RKE transmitter, and lock the doors again.

## Door Locks

### Unlock/Lock the Door Outside the Vehicle

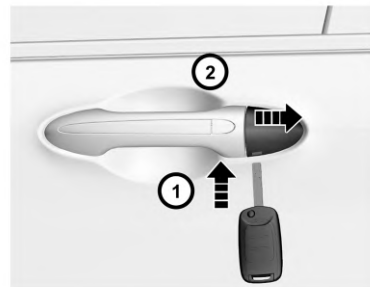

The lock hole on the left front door external handle is hidden under the trim cover. The trim cover needs to be removed first if the key is used to open the door; for example, the remote control is lost or out of power.

There is a small hole below the trim cover. Plug the key in the hole and press inward; at the same time, push the trim cover toward the vehicle to remove the cover. You can pull up the door handle and push the edge of the trim cover.

During installation, push and press the trim cover toward the front of the vehicle to fit the cover in place.

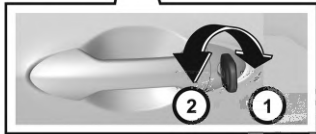

When locking the door, insert the key and turn it clockwise. Rotate the key counterclockwise to unlock the door.

### Caution

Do not leave children or pets alone in the vehicle. This may result in serious injury or death. Children could operate the power windows or other buttons or even make the vehicle move. Do not leave children

(Continued)

### Caution (Continued)

together with the key in the vehicle. All these behaviors may result in serious injury or death.

### Unlock/Lock the Door Inside the Vehicle

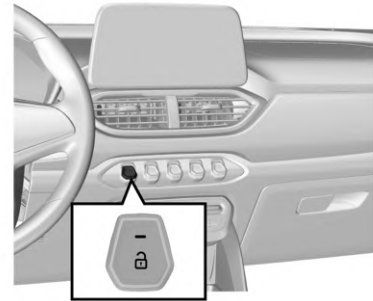
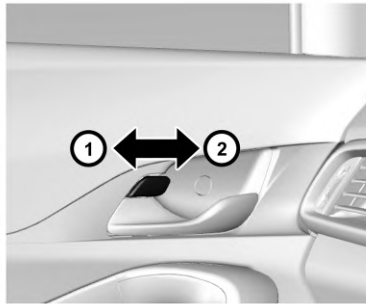

When locking the door inside the vehicle, press the door lock button on the internal handle of the door or press the central control lock button , and the indicator on the button will be turned off.

When unlocking the door inside the vehicle, move the door lock button outward or press the central control lock button , and the indicator on the button will be turned on.

If there is noise while opening/closing doors or driving, apply lubricating grease on the door catches and hinges.

When you leave the vehicle unattended, you must lock all doors and liftgate and take the RKE transmitter with you.

When the driver's door is opened, the door lock button can not be pressed. This is to prevent the door from being locked when the RKE transmitter is left in the vehicle.

### External/Internal Door Opening

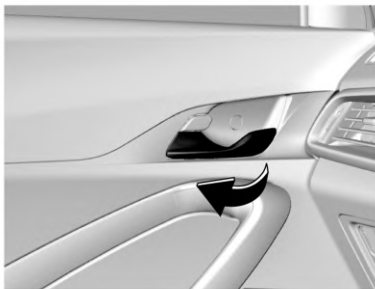
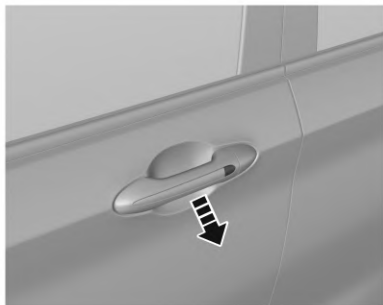

To open doors from inside or outside, unlock the doors first, and pull the external or internal door handles.

### Child Safety Lock



The rear doors are equipped with child safety locks. The function of the child safety lock is to prevent passengers (especially children) from pulling the door handle and accidentally opening the rear door from inside.

Both rear doors are equipped with door locks that must be activated manually.

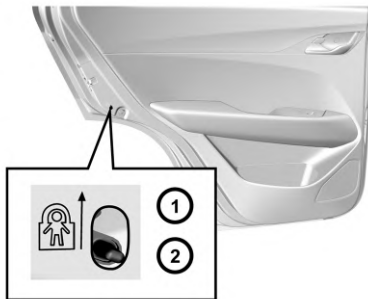

To activate the child safety lock:

1. Open the rear door that you want to lock.
2. Find out the child safety door lock lever on the door edge.
3. Slide the control lever to the locked position.

When the child safety lock is activated, you need to open the door with the external handle from the outside. When canceling the child safety door lock, turn the control lever to “unlocked” position.

When the child safety lock is activated, do not attempt to pull the internal door handle to open the door. Otherwise, the door handle may be damaged.

## Central Locking System

Through the central door lock system, you can lock and unlock the doors with the remote control outside the vehicle or with the central door lock switch inside the vehicle.

## Doors Hood

### Opening Engine Hood



1. Pull the engine hood release handle on the left lower side of the instrument panel, and the engine hood will be opened slightly.

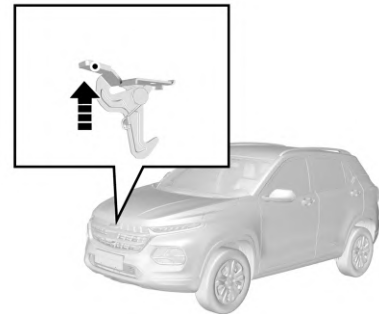

2. Reach your hand to the lower side of the engine hood front edge, as shown above, and lift the engine hood release handle up. Lift up and fully open the engine hood.



3. Separate the engine hood prop rod from the fixing clamp. Lift the prop rod up and firmly insert the free end into the slot on the engine hood.

### Closing Engine Hood

1. Support the engine hood to prevent it from closing, and take the prop rod out from the slot. Then, fix the rod in the fixing clamp.
2. Make sure hands and other body parts are away from the closed area of the engine hood.
3. Slowly lower the hood, and release it when the hood front edge is about 30 cm from the closed position.
4. Be sure to lock the engine hood in place and check for confirmation.

### Caution

The following precautions must be observed:

- Before driving, pull the front edge of the engine hood to make sure the engine hood is securely locked.

(Continued)

### Caution (Continued)

- Do not pull the engine hood release handle when the vehicle is in motion.
- Do not drive the vehicle with the hood open. An open hood will obstruct driver vision.

Driving with an open hood could lead to collisions that will damage your vehicle and other property and cause casualties.

## Liftgate

### Open the Liftgate

- Unlock the liftgate with keyless entry (if equipped): For vehicles equipped with Passive Entry Passive Start (PEPS) system, press the liftgate release switch.
- Unlock the liftgate with remote control: Press the unlock button to unlock the door, and then press the liftgate switch to open the liftgate.

You can also press and hold the liftgate unlock button  on the remote control for about two seconds to unlock the liftgate.

- Unlock the liftgate with central locking system: Unlock the door with the central locking button, and then press the liftgate switch to open the liftgate.

Make sure that you and other persons are out of the liftgate moving range to prevent personal injuries when the liftgate is popped open.

### Close the liftgate

When locking the liftgate, close it first, and then press the central locking button or the locking button on the key to lock it.

When closing the liftgate, make sure that your and other persons' hands and other body parts are completely out of the closing area to avoid any possible injury.

## Emergency Opening of Liftgate

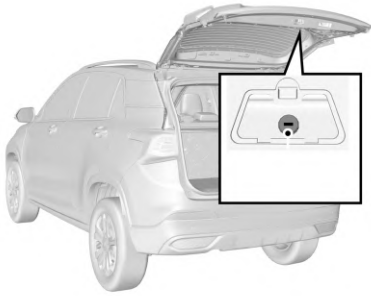

If other liftgate opening methods are not working, the liftgate can be opened urgently by:

Fold the rear seats, pry up the plastic trim cover outside the liftgate lock, and there is a knob with square groove inside. Insert the square tool of 8 mm × 8 mm into the groove and turn the knob clockwise. You can also use a wider key or iron piece to insert into the groove and turn the knob.

## Door Lock Thermal Protection

If the doors are unlocked/locked for over 10 times within eight seconds, the locks will be prohibited for ten seconds to protect them.

## Exterior Mirrors

### Power Mirrors

#### Outside Electrical Rearview Mirror

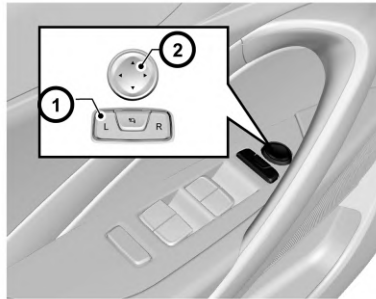

The rearview mirror adjustment switch is located on the door armrest panel on driver's side for upward, downward, leftward and rightward adjustments.

Check the visual field of all rearview mirrors before driving.

1. Make sure the ignition switch is in ACC or ON position.

2. Select the rearview mirror to be adjusted. Press the left button (L) to adjust the left mirror and press the right button (R) to adjust the right mirror.
3. Press the buttons around the setting pan to adjust the selected rearview upward, downward, leftward or rightward.
4. After adjustment, restore the selection switch to level state.

#### Folding

To ensure the pedestrian's safety, the outside rearview mirror can be rotate forward or backward from its normal mounting position under sufficient impact force. They can be reset by manually flipping the frame.

**Power Folding-Up (if equipped)**

Press the electric folding button  down, and the outside rearview mirrors are automatically folded. Press the button once again, and the mirror will be unfolded automatically.

**Automatic folding (if equipped)**

When the remote control is locked/unlocked, the outside rearview mirrors are automatically folded/unfolded. When the electric folding switch is pressed, the mirrors will not automatically unfold when the unlock button on the key is pressed.

**Defrosting of Outside Rearview Mirror (if equipped)**

The outside rearview mirrors of some models are equipped with defrosting function. While defrosting the rear windshield, the outside rearview mirrors are also defrosted. See *Climate Control Systems (Electronic Air Conditioning)* ⇨ 87.

**Notes to Electrical Folding of Frozen Outside Rearview Mirror**

In icy weather, if the outside rearview mirror is frozen, remove the ice first, and use the electric folding/unfolding functions. For example, if the mirror is frozen after the vehicle is parked outdoors for a night in winter, remove the ice first, and use the remote control or the passive entry button to unlock doors. Then, the outside rearview mirror will be unfolded smoothly. If the ice is not removed, the ice will hinder the movement of the rearview mirror, damaging the mirror.

If the outside rearview mirror glass is frozen, remove the freeze first, and then use the defrosting function for auxiliary heating and deicing. If the ice is not removed, the ice

will hinder the movement of the mirror while adjusting the mirror, causing damage to the mirror.

**Interior Mirrors****Interior Rearview Mirrors**

The interior rearview mirrors can be manually adjusted to an appropriate viewing angle.

The rearview mirrors of some models have anti-glare function. It reduces the glare of the strong headlights coming behind. Move the bottom switch forward to turn on the anti-glare function, and turn it back to restore.

The anti-glare mode will reduce the vision clarity behind the vehicle.

## Windows

### Power Windows

When the ignition switch is at the ON position, you can control the power window with the power window switch on each door armrest panel. You can also use the combination switch on the driver's side to control all windows. There are four window switches in the combination switch on driver's side, corresponding to the front, rear, left and right electric windows on the vehicle.

When the vehicle key is turned from the ON position to the ACC or LOCK position, or the key is removed, the window can still be controlled by the window switch within 30 seconds.

#### Caution

Children may get trapped by the power windows when operating it.

- Do not leave the key or unattended children in the vehicle.

Incorrect operation of power windows can lead to injuries.



To raise the window, pull upward the switch.  
To lower the window, press down the switch.  
When the window reaches the desired position, release the switch.

#### One-button Lowering of Driver's Side Power Window

The driver's side power window has the one-button lowering function. When opening the window, press the switch to the bottom (the 2nd gear) and then release the switch.

The window glass will automatically drop until the window is fully open. To stop lowering the window, pull upward the button and release (short pull is ok).

#### Remote Lowering of Power Window

Press and hold the unlock button on the remote control key for about 2 seconds to lower all window glass in turn.

#### Note

Make sure that your hands and any other body parts, as well as those of other persons are completely away from a power window so as not to get caught by a moving window.

#### Power Window Lock Button

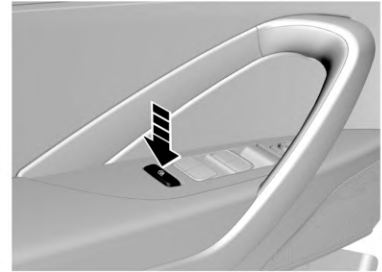

The electric window lock button can be pressed to lock the rear window and the switch of front passenger-side window. When the button is pressed, the rear windows and front passenger-



side window can only be controlled by the window control panel on driver's side. Press again to unlock.

### Caution

Children could operate the power windows and become trapped by the windows, resulting in serious injuries.

Use the power window lockout when children are travelling in the rear seats.

## Sun Visors

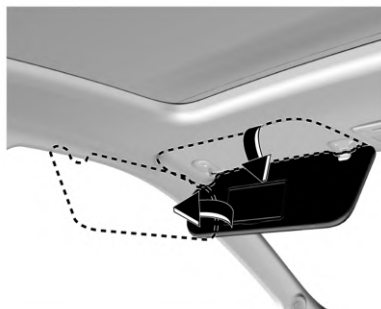

Your vehicle is configured with sunshade which can reduce dazzling effect on the driver and passengers.

The sunshade can move upward, downward and sideward. Some sunshades also have bill fold and makeup mirror.

## Auxiliary Handrails

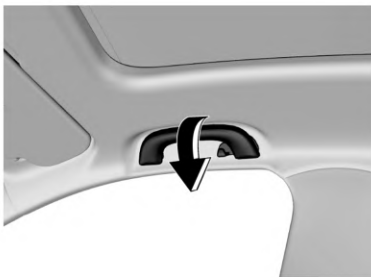

Above the front passenger's side door and rear doors, an auxiliary handrail is installed. Coat hooks are attached to some armrests.

The auxiliary handrail is convenient for passengers to get in and out of the vehicle. The passengers can also grab the handrail to help maintain the sitting position when the vehicle speed is fast.

While using the folding auxiliary handrail, hold it downward. When it is released, it will return automatically.

Armrests are fixed on some of the low-configuration vehicle models and cannot be folded.

## Roof

### Sunroof

#### Power Sunroof (if equipped)

When the ignition switch is at ON position, the sunroof glass can be operated.

### Warning

The following must be observed:

- Do not stick any part of your body parts or objects out of the sunroof.
- Ensure that there is no object inside or outside the sunroof before closing.
- Do not place heavy object on or around the sunroof.

(Continued)

**Warning (Continued)**

- Ensure there is no object at the outside of the sunroof.
- Close the sunroof completely when the vehicle is left unattended.

All passengers must wear the seat belts whether the sunroof is open or closed as in other situations. Violation of the matters above will cause serious injuries or damage to the vehicle.

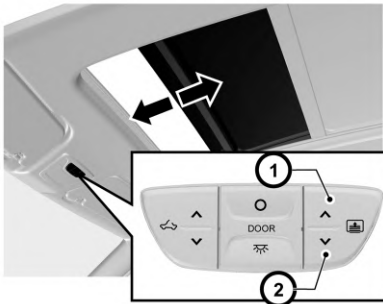
**Sun Blind**

Press the open or close button of the sun blind to slide open or close the sun blind. When it reaches the desired position, release the button.

Short press the button, and the sun blind can be opened or closed automatically.

**Sunroof**

The sunroof is composed of two parts—the front part is tiltable and slidable while the rear part is fixed.

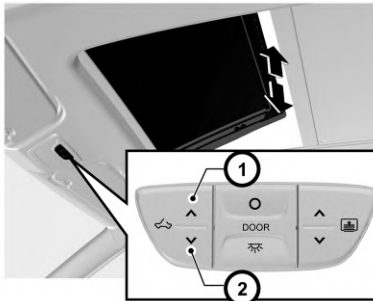
**Sunroof Tilting**

The front part of the sunroof glass can be tilted.

To tilt open the sunroof, press the sunroof open button when the sunroof is completely closed, and release the button when the sunroof reaches the desired position. To completely tilt the sunroof, press and hold the button, and then release the button when the sunroof stops moving.

You can also quickly press the open button (short press) and the sunroof will be tilted opened automatically. To close the tilted sunroof, press and hold the sunroof close button, and release it when reaching the desired position. To completely close the sunroof, release the button when the sunroof stops moving.

### Sunroof Sliding

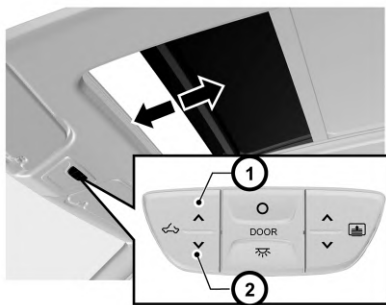

The sunroof can slide open backward after it is completely tilted open.

To slide-open the sunroof, press the sunroof open button, and release it when reaching the desired position. You can also quickly press the open button (short press) and the sunroof will slide-open automatically.

To slide-close the sunroof, press the sunroof close button, and release it when reaching the desired position. To completely close the sunroof, release the button when the sunroof stops moving. You can also quickly press the close button (short press) and the sunroof will slide-closed automatically.

### One-button Opening or Closing

Push the “OFF” or “ON” button once quickly (short press) while operating the sunroof switch, and the sunroof can be closed or opened automatically.

When opening, press the open button (short press) to open slantwise, and press again to sliding-open. If the sunroof open button is short pressed for the first time after the vehicle is powered on, the sunroof will be automatically open completely.

When closing, press the close button (short press), and it will be closed automatically and completely.

When opening or closing automatically, if you need to stop, just press the button again.

### Anti-pinch Function

The sunroof and the sun blind will retract to reduce pinching risks when they contact a certain rigid obstacle (such as the arm and head) in the one-button closing or remote closing process.

After the sunroof or sunshade is anti-pinch protected for continuously three times, the anti-pinch function is temporarily eliminated.

Long press the switch to open or close. After manually closing the sunroof, the function recovers.

### Remote Sunroof Opening and Closing

Press the unlock button/lock button of the remote control for about two seconds, the sunshade and sunroof will completely be opened/closed automatically.

### Linkage Function

The interlocking function of the sunroof and sunshade allows the sunshade to be positioned rearward relative to the sunroof glass during the moving of the sunroof.

This function allows you to observe the sunroof that is not closed, so as not to forget to close the sunroof when leaving the vehicle.

### Shutdown Delay Function

The sunroof and sunshade can be operated within 30 seconds.

### **Sunroof Initialization Learning**

The sunroof or the sun blind may lose its one-button opening or closing function in some cases, such as replacement of sunroof glass or motor. In such cases, the sunroof initialization learning will be conducted first

Move the sunroof or sunshade until it is completely closed. Press and hold the close button of the sunroof or sunshade for about 12 seconds until you hear it closed completely.

If the one-button opening or closing function still cannot be recovered after initialization learning, see your dealer.

## Seats and Restraints

### Head Restraints

Head Restraints ..... 20

### Front Seats

Seat Position ..... 21

Seat Adjustment ..... 21

### Rear Seats

Rear Seats ..... 23

### Seat Belts

Seat Belts ..... 24

Lap-Shoulder Belt ..... 25

Seat Belt Use During Pregnancy ..... 26

### Airbag System

Airbag System ..... 27

Where Are the Airbags? ..... 28

When Should an Airbag Inflate? ..... 29

What Makes an Airbag Inflate? ..... 29

How Does an Airbag Restrain? ..... 29

What Will You See After an Airbag

Inflates? ..... 30

### Child Restraints

Infants and Young Children ..... 34

Child Restraint Installation Locations ..... 37

ISOFIX Child Restraint Systems ..... 38

## Head Restraints

### Position



The middle position of the headrest should be on the same horizontal line as the occupant's eyes. For tall persons, if the above point cannot be met, the headrest shall be adjusted to the highest position; for short persons, the headrest shall be adjusted to the lowest position.

### Danger

With head restraints that are not installed and adjusted properly, there is a greater chance that occupants will suffer a neck/spinal injury in a crash. Do not drive until the head restraints for all occupants are installed and adjusted properly.

### Height Adjustment (if equipped)

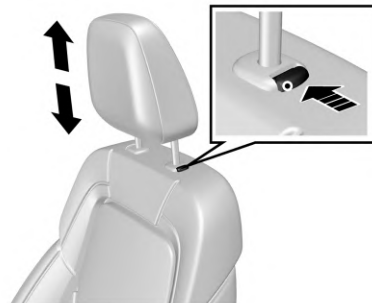

To adjust the headrest upward, pull the headrest upward to a proper position and fix it. To remove the headrest, press and hold the release switch.

To adjust the headrest downward, press and hold the release switch and push the headrest downward to a proper position; then, release the switch. Pay attention not to press the headrest forcibly to avoid injuring the finger pressing the release switch. The headrests of the rear bench-seat are fixed and the height cannot be adjusted.

## Front Seats

### Seat Position



- When you sit on the seat, move your hips as close to the backrest as possible. Adjust the distance between the seat and the pedal to

make your leg slightly bend when you press the pedal. The passenger's seat shall slide as backward as possible.

Correctly adjust the seat before driving.

- When you sit on the seat, adjust your shoulders flat against the seat. Set the backrest inclination angle to make your arm conveniently reach the steering wheel while slightly bending the arm. Keep the shoulder leaning against the backrest while turning the steering wheel. The backrest shall not incline excessively backward. It is recommended that the inclination angle of the backrests does not exceed 25 degrees.
- The seat height shall be so set that the occupant can see all directions and the positions of all display instruments. The head must be at least one hand away from the roof lining. The thighs are right on the seat without constriction.

Never adjust the seat when the vehicle is running because the seat may not move as controlled.

## Seat Adjustment

### Manual Adjustment Type (if equipped)



Pull upward the adjustment lever on the front lower part of the seat to adjust the seat forward or backward, and release the lever after the seat is adjusted to a proper position.

Try to slide the seat forward and backward to ensure that the seat is locked at a proper position.

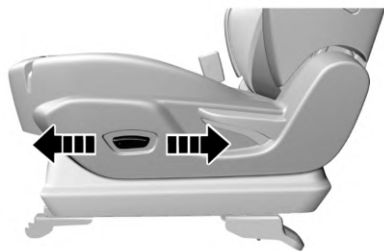
**Electric Adjustment Type (if equipped)**

The electric adjustment switch is on the outer side of the seat. Push the switch forward or backward, and the seat will move forward or backward accordingly. Release the switch when it reaches a proper position.

**Seat Backrest Adjustment**

Pull up the lever and adjust the tilt angle of the backrest to a proper position, and then release the lever. Do not lean on the seat backrest while adjusting. After adjusting the backrest, lean back on it to ensure that it is locked in place.

 **Warning**

If either seat backrest is not locked, it could move forwards in a sudden stop or crash. This may cause injury to the person sitting there. Always push and pull the seat backrest to be sure they are locked.

**Driver's Seat Height Adjustment  
(if equipped)****Manual Adjustment Type**

When adjusting the position of driver's seat cushion, lift or lower the handle on the side of the seat cushion until adjusting to the desired position. When adjusting the driver's seat height, the seat must be loaded, otherwise the adjustment device may be damaged.

### Electric Adjustment Type (if equipped)



Rotate the height adjustment switch on the outer side of the seat cushion, and then release the switch after the seat is adjusted to the required height. Turn the switch counterclockwise to lower and clockwise to raise.

### Rear Seats

#### 60/40 Seat

#### Backrest Adjustment



There are backrest unlocking straps on left and right sides of the 6/4 rear seat, and pull the strap to unlock the corresponding backrest.

After unlocking the backrest, it can be adjusted within a certain angle range. Then release the strap after adjustment. Try to shake the backrest to ensure that it is locked.

You can also pull the unlocking strap and fold the backrest forward. When unfolding the backrest, pull the strap, position the backrest, and then release the strap.

#### Seat Cushion Overturn



Pull the front of the seat cushion slightly to unlock and lift the seat cushion.

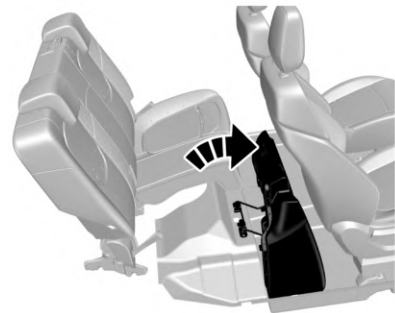



As shown in the figure, after the cushion is unlocked, pull out the cushion forward and lift up the rear part of the cushion to overturn it. Both cushions can be overturned like this.

When restoring, install the cushion in opposite order. Press the front of the seat cushion with force to lock it.

At last, try to shake the seat cushion to ensure that it is locked.

#### Flatten the Backrest

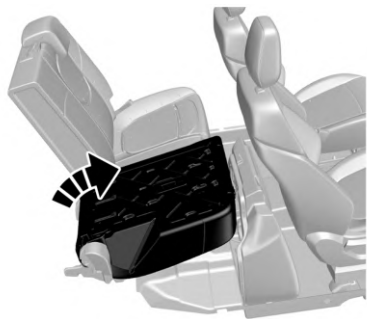

Flip the cushion first, then pull the backrest strap to unlock the backrest, and then fold the backrest forward until it is flat. Both backrests can be folded and laid flat.

Operate in the reverse order when restoring. Try to shake the backrest and cushion to ensure that they are locked.

#### Seat Position and Backrest Angle for Measurement of Seat Cushion Thickness

For measurement of the seat cushion thickness, the seat can be in any position.

The seat backrest angle state is 25 degrees backward in the vertical state.

#### Restore the Rear Seat Backrest

1. To prevent the seat belt from being caught when restoring the backrest, pull up the seat belt first to avoid the area where the backrest is unfolded.
2. Lift the seat backrest and push it back to its original position.
3. Push the upper part of the backrest back with slight force to lock the backrest.
4. Try to shake the backrest to ensure that it is locked.

#### Seat Layout Diagram

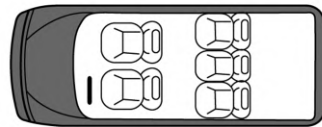

#### Seat Belts



The seat belt is designed only for one passenger. It is not applicable to a passenger under 12 years old or under 150 cm high. Check all parts of the seat belt system for damage and abnormal function regularly. Replace the damaged parts and components. To replace or service a seat belt, see your dealer.

#### Seat Belt Force Limiter (if equipped)

It is configured on the seat belts for the driver's seat and the front passenger's seat.

The force limiter can reduce the stress applied on the body through the seat belt damping release in case of a collision accident.

#### Seat Belt Pretensioner

It is equipped on the front seat belt according to the vehicle configuration.

In case of a severe head-on or rear-end collision, the front part of the seat belt will be tensioned.

The activated seat belt pretensioner must be replaced by your dealer. The seat belt pretensioner can only be deployed once.

Make sure that the seat belt is not damaged or clamped by a sharp object. Prevent dust from getting in the seat belt retractor.

#### Warning

Improper operation (such as removal or installation of a safety belt or safety belt anchor) may trigger the belt tensioner and lead to injury.

#### Warning

Buckle the seat belt each time before driving the vehicle. In case of an accident, a passenger who does not buckle the seat belt may be at risk.

#### Warning

The seat belt shall not be buckled against a hard or fragile object in your pocket. Otherwise, the hard object will hurt you and the fragile object may be damaged in case of emergencies.

## Lap-Shoulder Belt

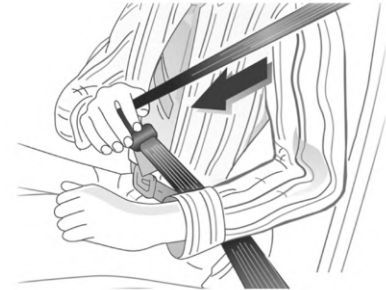

Pull the seat belt out of the retractor, guide it around the body without twisting, and insert the locking tab into the buckle to fix it. When driving, pull the shoulder belt forcibly to adjust the tightness of hip belt.

Loose or heavy clothing will hamper close wearing the seat belt. Do not place any object (such as hand bag and mobile phone) between the seat belt and your body.

### Unbuckle

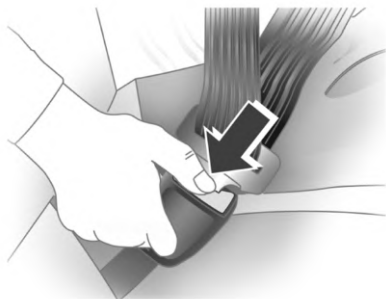

To unbuckle the seat belt, press the red button on the buckle.

### Rear Seat Belt

For buckling and unbuckling of the left and right seat belts of the rear row, refer to the front seat belt.

For the middle position of rear seat belt:

1. Pull the seat belt out of the retractor on the backrest.

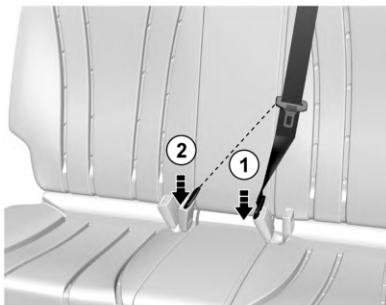

2. After the passengers are seated, insert the spring bolt (1) first at the top of the seat belt into the buckle on the left side of the seat.

The buckle is different from other buckles, and the red release button is on the side of the buckle.

3. Insert the movable spring bolt into the buckle on the right side of the seat (2). Ensure that the seat belt bypasses the front chest and anchors properly.

### Seat Belt Use During Pregnancy

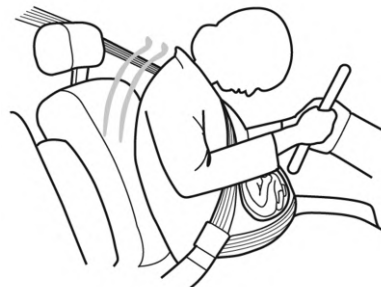

The seat belt provide protection for everybody, including a pregnant woman. Like all passengers, if pregnant women do not wear the seat belt, severe personal injuries are more likely be caused to them.

The pregnant woman must wear the hip/shoulder seat belt during the whole pregnancy, and the hip belt shall be fastened as low as possible. The best way to protect a fetus is to provide safety protection to its mother. If

the seat belt is fastened correctly, the fetus is not vulnerable to injury in case of a collision. For a pregnant woman or any person, correct wearing is the key to exert the best protection effect of the seat belt.

The hip belt must be placed as low as possible to go across the pelvis, so as avoid force on the belly.

## Airbag System

The vehicle has the following airbags:

- Driver frontal air bag.
- Front passenger frontal air bag.  
(If equipped)
- Front side air bag. (If equipped)

For all air bags, the letter “AIRBAG” is marked on the trim panel or the label near to its deployment opening. For frontal air bags, the letter “AIRBAG” for the driver is located in the middle of the steering wheel, and that letter “AIRBAG” for the front passenger is located on the instrument panel. For lateral-impact air bags, the letter “AIRBAG” is located on the backrest side, near to the door.

The air bag can supplement protection on the basis of correcting wearing the seat belt. Although nowadays the air bags are designed to reduce the injury risks caused by the impact force when the air bag is inflated, all air bags must be inflated rapidly to exert its effect.

The important notes about the air bag system are as follows:

### Danger

You can be severely injured or killed in a crash if you are not wearing your seat belt, even with airbags. Airbags are designed to work with seat belts, not replace them. Also, airbags are not designed to inflate in every crash. In some crashes seat belts are the only restraint.

Wearing your seat belt during a crash helps reduce your chance of hitting things inside the vehicle or being ejected from it. Airbags are “supplemental restraints” to the seat belts. Everyone in the vehicle should wear a seat belt properly, whether or not there is an airbag for that person.

### Danger

Do not let a child, infant, pregnant woman, or the sick and weak sit on the front seat equipped with an air bag. Never install a backward-facing child seat on the front seat. The child may be seriously injured or killed when an air bag is inflated. The seat belt and air bag can protect adults and adolescents but not children and infants. Children and infants need special child protection devices, such as a child seat, to get corresponding protection.

### Warning

Since the airbag is inflated faster than the blink of an eye and is accompanied by a huge impact force, if the passenger is close or sitting close to the airbag, he/she may be seriously injured or even killed due to the inflation of airbag. Do not sit too close to the airbag, such as sitting on the edge of the seat or leaning forward. Wearing the seat belt can help you stay in the right position before and during a collision. Even

(Continued)

**Warning (Continued)**

the vehicle is equipped with airbags, the seat belt must be worn. The driver should sit back as far as possible while ensuring that the vehicle can be operated normally. For vehicles equipped with side airbags, the passenger must not lean on the door.

**Airbag indicator**

On the instrument panel, there is an air bag indicator which displays the air bag shape symbol. The system will check whether the air bag circuit system has a fault

and give corresponding prompt through the indicator. Refer to the Chapter “Instruments and Controls” for detailed information.

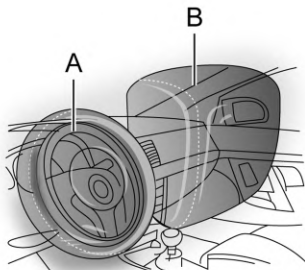
**Where Are the Airbags?****Frontal Air Bag**

As shown in the Figure A above, the driver frontal air bag is located in the middle of the steering wheel.

As shown in the Figure B above, the front passenger frontal air bag is located in the passenger's side instrument panel.

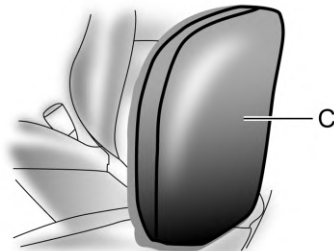
**Side Air Bag**

As shown in the Figure C, the front seat side air bag is installed on the backrest side near to the door.

**⚠ Danger**

If there is any object between the occupant and the air bag, the air bag may not inflate normally or the air bag may cause the object to squeeze the occupant's body when it is inflated, leading to severe injuries or even death. Please never use a seat accessory (such as seat jacket) that may hinder the inflating of the lateral-impact air bag.

## When Should an Airbag Inflate?

The frontal air bag is designed to be inflated in moderate to severe head-on collision or almost head-on collision to reduce severe injury risks of the driver's and the front passenger's head and chest.

Whether the frontal air bag is inflated depends on the vehicle running speed. It depends on the impacted object, impact direction and vehicle deceleration during collision.

The frontal air bag may be inflated in different collision speed. The air bag inflation depends on the impact direction (straight or in certain angle) at the moment of collision and whether the impacted object is fixed or movable, deformable or not and narrow or wide. Due to different design of each vehicle, the collision inflation conditions of the frontal air bag may vary. The frontal air bag will not be inflated in case of vehicle overturn, rear-end collisions and most lateral-impact collisions. The frontal air bag may not be inflated in slight head-on or nearly head-on collisions, lateral or diagonal collisions, collisions to cylindrical objects (such as pole and tree trunk), rear-end collisions under large vehicle (trucks, etc.) and lateral glancing collisions.

As per the design, the seat lateral-impact air bag will be inflated according to the impact position in case of the moderate to severe lateral collisions.

The seat lateral-impact air bag will not be inflated in case of head-on collisions, nearly head-on collisions, vehicle overturn or rear-end collisions. The seat lateral-impact air bag may not be inflated in slight side collisions and lateral-frontal or diagonal collisions. As per the design, the seat lateral-impact air bag will be inflated on the side of the collision. The air bag will not be triggered in all collision accidents. For a particular accident, it shall not simply judge whether the air bag should be inflated according to the causalities, vehicle damage or repair and maintenance expenses. Your vehicle is equipped with a collision sensing and diagnosis module. If a collision accident reaches certain strength, the module may record relevant collision information after the collision. If you have any doubt on the working situation of your air bag in a collision accident, contact your dealer to provide professional analysis and diagnosis for you.

## What Makes an Airbag Inflate?

In the inflation process, the sensing system will send an electronic signal to trigger the gas generator; the generator will release gas to inflate the air bag and to make the air bag pops up from the cover plate. The gas generator, air bag and relevant members are all components of the air bag module.

## How Does an Airbag Restrain?

In moderate to severe frontal or near-frontal collisions, even if wearing the seat belt, the passenger may also bump into the steering wheel or dashboard. In moderate to severe side impacts, even if wearing the seat belt, the passenger may also bump into internal vehicle components. The air bag supplements protection provided by the seat belt by distributing the impact force more evenly to the occupant's body. However, some occupants' bodies do not move toward the air bags in collisions where an external object intrudes into the vehicle. The air bag cannot provide corresponding protection. See *When Should an Airbag Inflate?* ⇨ 29 The air bag shall only be deemed as a supplementary device of the seat belt.

## What Will You See After an Airbag Inflates?

After frontal and seat-mounted side impact airbags inflate, they quickly deflate, so quickly that some people may not even realize the airbags inflated. Some components of the airbag module may be hot for several minutes.

The parts of the airbag that come into contact with you may be warm, but not too hot to touch. There may be some smoke and dust coming from the vents in the deflated airbags. Airbag inflation does not prevent the driver from seeing out of the windshield or being able to steer the vehicle, nor does it prevent people from leaving the vehicle.

### Danger

When an airbag inflates, there may be dust in the air. This dust could cause breathing problems for people with a history of asthma or other breathing trouble. To avoid this, everyone in the vehicle should get out as soon as it is safe to do so. If you have breathing problems but cannot get

(Continued)

### Danger (Continued)

out of the vehicle after an airbag inflates, then get fresh air by opening a window or a door. If you experience breathing problems following an airbag deployment, you should seek medical attention.

If the vehicle power supply system can still function normally after a collision, the vehicle has the functions of unlocking doors automatically, turning on the hazard warning lamp and cutting off the fuel system after the air bag is inflated. The driver can use corresponding function switch to lock doors, turn off indoors lamps and turn off the hazard warning lamp.

### Warning

Some of the vehicle's important functions, such as power, braking and steering systems, would also be damaged in severe crashes that causing airbag inflation. Even if the vehicle can also be driven after collision, there may be some invisible damage that

(Continued)

### Warning (Continued)

resulting in the inability to operate the vehicle safely. Take care to drive the vehicle after collision.

In many collisions that are severe enough to trigger airbags, the windshield would break due to vehicle deformation. The deployment of the front passenger air bag may also cause damage to the windshield.

- The air bag can only be inflated once as per its design. After the air bag is inflated, some parts of the air bag system need to be replaced. If you do not have these parts replaced, the air bag system will unable to provide protection in next collision accident. The air bag system parts that shall be replaced include the air bag module, air bag control module, seat belt pretensioner and other parts.
- The vehicle is equipped with collision sensing and diagnostic modules that recording information after collision.
- Work related to the air bag system can only be done by technicians with corresponding qualification. Improper

repair and maintenance may cause that the air bag system cannot function normally. See your dealer for repair and maintenance.

### Air Bag System Repair, Maintenance and Replacement

The air bag system must be maintained by qualified and professional technicians. Improper maintenance will cause that the air bag system cannot function normally. See your dealer for repair and maintenance of the air bag system. The air bag can only be inflated once. After the air bag is inflated, some parts of the air bag system need to be replaced. If you do not have these parts replaced, the air bag system will be unable to provide protection in next collision. Ensure that the airbag fault warning lamp is working properly. If the airbag fault warning lamp is always on while starting the vehicle or driving, then the airbag system may not work properly. The vehicle needs to be repaired immediately.

#### Caution

If the air bag cover is damaged, opened or broken, the air bag may not function normally. It should be repaired as soon as possible.

Never try to repair, adjust, remove or install any air bag system component. Never try to refit the front bumper of the vehicle body by yourself. Never stick or cover any object on the air bag cover surface or refit the air bag cover.

#### Other Situations Where the Air Bag May Be Inflated (Deployed) Except for Collision

If the vehicle bottom is impacted seriously, the air bag may also be inflated. Refer to the following examples.

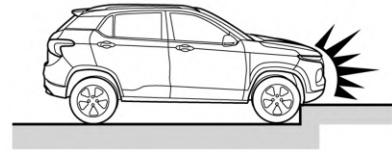

- Hit a road shoulder, sidewalk edge or hard surface.

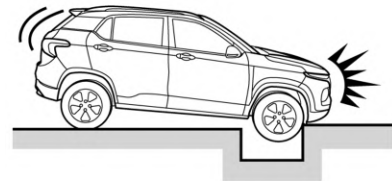

- Fall into or drive into a deep pit.



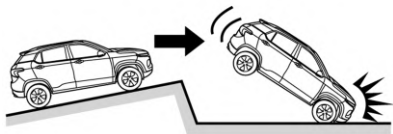

- Wheel hard landing or vehicle fall.

### The Frontal Air Bag May not Be Inflated in the Following Collisions

The frontal air bag will usually not be inflated in case of side collisions, rear-end collisions, turnover or low-speed head-on collisions. No matter what kind of collision, only when the vehicle generates sufficient forward deceleration, will the frontal air bag be inflated.

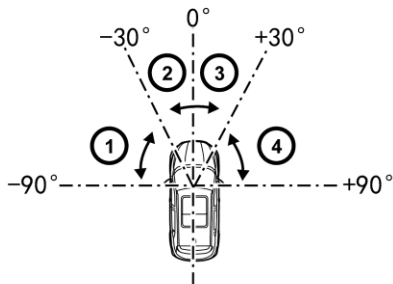

- Head-on collision angle over 30° from vehicle longitudinal direction

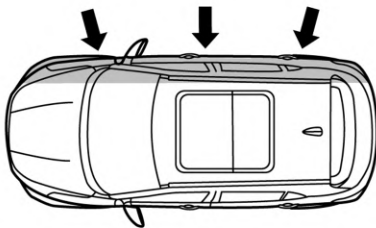

- Side collision.

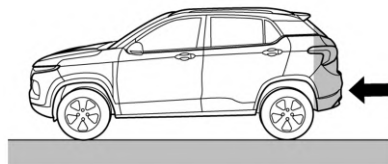

- Rear-end collision.

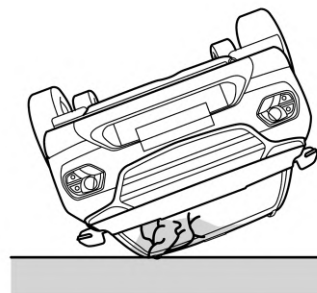

- Overturn, falling from high place, rolling.



- Hit deformed objects, such as sand pile, guard bar, column and tree.

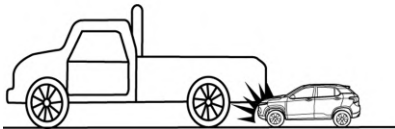

- Hit into front vehicle bottom, especially truck bottom.

### Side Air Bag May not Be Inflated in the Following Collisions

In case of side collisions with certain angle or collisions to vehicle body side (not passenger compartment), the side air bag system may not be activated.

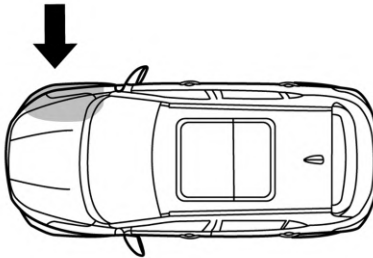

- Vehicle body side (not passenger compartment) collision.

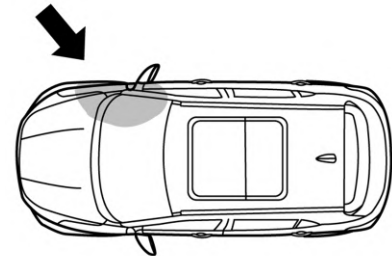

- Off-vertical side collision.

The side air bag will usually not be inflated in case of head-on collision, rear-end collisions, overturn or low-speed side collisions.

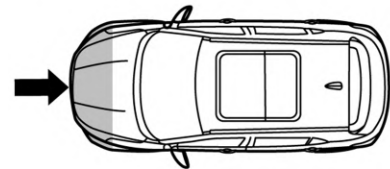

- Head-on collision.

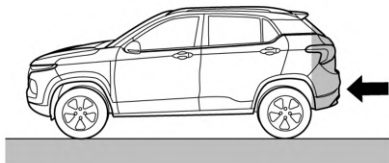

- Rear-end collision.

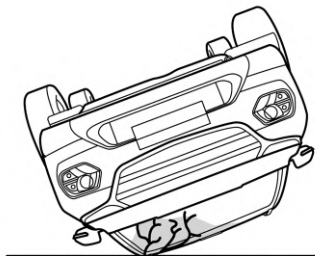

- Overturn, falling from high place, rolling.

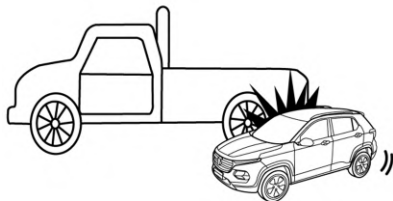

- Side collision to truck during drifting.

#### Important Note



Do not use a backward-facing child restraint system on a seat (front seat) protected by a frontal air bag (in activated state). Otherwise, severe injuries or even death may be caused to the child when the air bag is deployed.

## Child Restraints

### Infants and Young Children

#### Child Seat

The vehicle is not equipped with a child seat. If you want to add one, a child seat that is applicable to ISOFIX “general” type can be selected. The child seat can only be placed on the second row seat. The front seat is not equipped with the anchor system bracket. The statistical data of accidents show that placing the child seat on the rear row seat can largely improve the child safety.

For a small child, a child seat should always be used. Never hold a child in your arms while riding in the vehicle. Never allow a child to stand or kneel on a seat or in the luggage compartment when the vehicle is running.

**Caution**

An unsecured child seat may be thrown out of the vehicle when a collision or emergency stop occurs. The child seat must always be correctly secured, even if it is not used.

If the child seat is put in a closed compartment in hot weather, the child seat temperature will be very high. Make sure that the child seat temperature is not very high before putting a child in the seat. If the child is too small and the seat belt cannot provide the best protection for it, make sure that a proper child seat is used to provide safety protection.

**Warning**

The size and configuration range of a child seat may vary drastically. Not all child seats are applicable to your vehicle due to the effects of the vehicle trim as well as the seat shape and size. A child can be seriously injured or killed in a crash if the child restraint is not properly secured in

(Continued)

**Warning (Continued)**

the vehicle. Secure the child seat properly in the vehicle following the instructions that came with that child restraint and the instructions in this manual. If the child seat does not match with your vehicle size and the child body figure or the connection to your vehicle is incorrect, severe personal injuries may occur to the child and other passengers in the vehicle in case of a collision.

**Child Seat Recommendations**

The company recommends the use of these two child seats: Britax Baby Safe Plus ISOFIX Base and Britax Duo Plus. They are certified by ECE R44, and can provide better protection for the child.

Section 1: Britax Baby Safe Plus ISOFIX Base  
Group 0+ up to 13 kg

Installation Method:

Installed in the side position of the 2nd-row seat.

Use ISOFIX interface to connect the seat and adjust the height to ensure that the support leg is securely mounted on the floor of the vehicle.



Section 2: Britax Duo Plus

Group I – 9–18 kg

Installation Method:

Installed in the side position of the 2nd-row seat.

Only install with ISOFIX interface and pull-up straps provided with child seats.

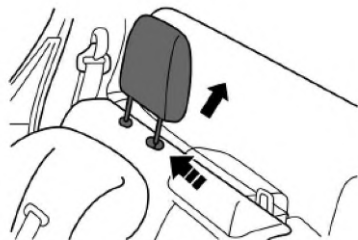

When installing the child seat, it is recommended to remove the headrest.

### Child Restraint Systems Classification



Infants and children should be placed in the rear seat and properly restrained.

#### Warning

A child in a rear-facing child restraint can be seriously injured or killed if the front passenger airbag inflates. This is because the back of the rear-facing child restraint would be very close to the inflating airbag. A child in a forward-facing child restraint

(Continued)

#### Warning (Continued)

can be seriously injured or killed if the front passenger airbag inflates and the passenger seat is in a forward position.

Even if the passenger sensing system has turned off the front passenger frontal airbag, no system is fail-safe. No one can guarantee that an airbag will not deploy under some unusual circumstance, even though it is turned off.

Secure rear-facing child restraints in a rear seat, even if the airbag is off. If you secure a forward-facing child restraint in the front seat, always move the front passenger seat as far back as it will go. It is better to secure the child restraint in a rear seat.

#### Danger

NEVER use a rearward-facing child restraint on a seat protected by an ACTIVE AIRBAG in front of it; DEATH or SERIOUS INJURY to the CHILD can occur.

## Child Restraint Installation Locations

Permissible options for fastening a child restraint system at different seating locations

Group	Weight Range	Seat Position		
		Front Passenger	2nd Row Outside	2nd Row Middle
Group 0	≤10 kg	X	U	X
Group 0+	≤13 kg	X	U	X
Group I	9–18 kg	UF	U	X
Group II	15–25 kg	UF	U	X
Group III	22–36 kg	UF	U	X

**U:** Suitable for "universal" category restraints approved for use in this mass group.

**UF:** Suitable for forward-facing "universal" category restraints approved for use in this mass group.

**L** Suitable for particular child restraints given on attached list. These restraints may be of the "specific vehicle", "restricted" or "semi-universal" categories.

**B** Built-in restraint approved for this mass group.

**X:** Seat position not suitable for children in this mass group

## ISOFIX Child Restraint Systems

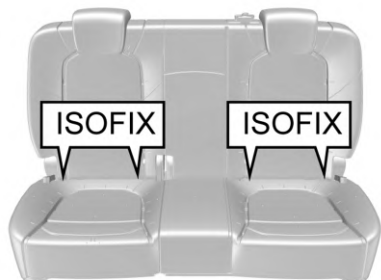

To fix the child seat:

1. The ISOFIX lower fixing point is on the joint between the rear row set backrest and the seat cushion back. Its position can be identified through the label on the lower edge of the backrest. The left and right seats are equipped with a set of ISOFIX respectively.
2. Clear up the objects on the seat. Note to remove the seat belt and seat belt buckle to avoid affecting accurate fixing of the child seat.
3. Put the child seat on the second row seat.

4. Connect the fixing hook on the child seat to the on-vehicle fixing device. Operate according to the child seat instructions.

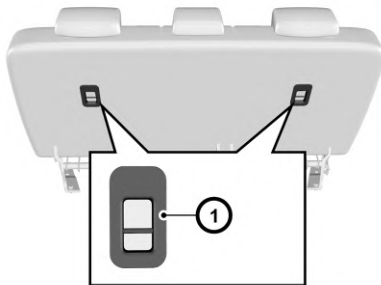

5. Connect the upper strap of the child seat to the corresponding fixing point of the vehicle. Refer to the child seat instructions to get to know when and how to strain the upper strap. As shown, the attachment point of child seat is located behind the rear seat backrest.
6. Push and pull the child seat in all directions to make sure it is safely secured.
7. Make sure that the child seat temperature is not very high before putting a child in the seat.

In case of a serious collision accident, the ISOFIX may be damaged. It may be necessary to repair and replace some parts. Check the ISOFIX after a collision.

**ISOFIX Position**

ISOFIX child restraint system size, classes, and fixtures.

ISOFIX size rating	Fixed module (CRF)	Size range
A	ISO/F3	Full-Height Forward Facing toddler CRS
B	ISO/F2	Reduced-Height Forward Facing toddler CRS
B1	ISO/F2X	Reduced-Height Forward Facing toddler CRS
C	ISO/R3	Full-Size Rearward Facing toddler CRS
D	ISO/R2	Reduced-Size Rearward Facing toddler CRS
E	ISO/R1	Rearward Facing infant CRS
F	ISO/L1	Left Lateral Facing position CRS (carry-cot)
G	ISO/L2	Right Lateral Facing position CRS (carry-cot)



### ISOFIX Child Seat Location

Weight category	Size class	Device	Seat Position		
			Front Passenger	2nd Row Outside	2nd Row Middle
Carry-cot	F	ISO/L1	X	X	X
	G	ISO/L2	X	X	X
Group 0 (up to 10 kg)	E	ISO/R1	X	IL	X
Group 0+ (up to 13 kg)	E	ISO/R1	X	IL	X
	D	ISO/R2	X	IL	X
	C	ISO/R3	X	IL	X
Group I (9–18 kg)	D	ISO/R2	X	IL	X
	C	ISO/R3	X	IL	X
	B	ISO/F2	X	IUF/IL	X
	B1	ISO/F2X	X	IUF/IL	X
	A	ISO/F3	X	IUF/IL	X
Group II-III (15–36 kg)			X	IL	X

## Storage

### Storage Compartments

Instrument Panel Storage .....	41
Glove Box .....	42
Cupholders .....	42
Front Storage .....	42
Rear Storage .....	43
Floor Console Storage .....	43

### Luggage/Load Locations

Luggage Compartment .....	44
---------------------------	----

### Additional Storage Features

Shopping Bag Hooks .....	45
--------------------------	----

### Roof Rack System

Roof Rack System .....	45
------------------------	----

### Information on Loading the Vehicle

Information on Loading the Vehicle .....	46
--	----

## Storage Compartments

### Instrument Panel Storage

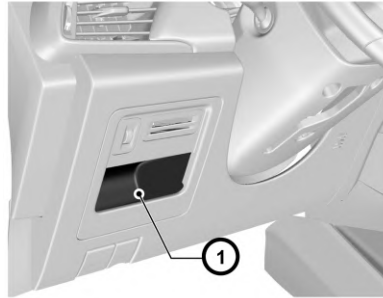

A storage box is located under the left side of the dashboard.

### Instrument Panel Central Storage Box

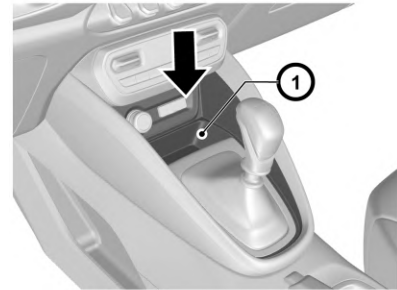

A storage box is located under the middle of the dashboard.

## Glove Box



Pull the handle outward to open it. To close, push and fasten the glove box door inward.

### Warning

Keep the glove box door closed when the vehicle is moving to reduce the injury risks due to emergency braking or in case of a crash.

## Cupholders

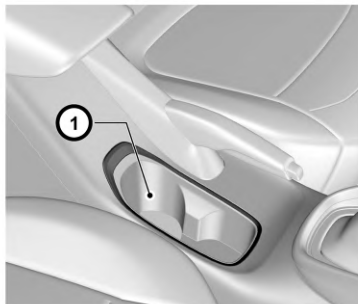

The cup holder is located on the console between the front seats.

### Warning

Do not place uncovered cups of hot liquid in the cup holder while the vehicle is in motion. If the hot liquid spills, you burn yourself. Such a burn to the driver could lead to loss of control of the vehicle.

(Continued)

### Warning (Continued)

To reduce the risk of personal injury in the event of a sudden stop or collision, do not place uncovered or unsecured bottles, glasses, cans, etc., in the cup holder while the vehicle is in motion.

## Front Storage



The door storage groove 2 and armrest 1 are located on inner side of the door panel.

### Card Slot

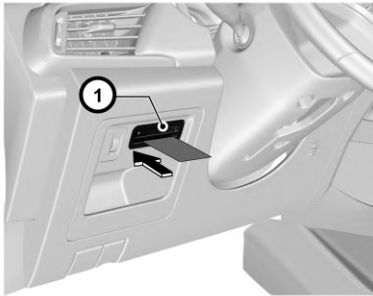

On the left side of the instrument panel, there is a card slot for card placing.

### Rear Storage

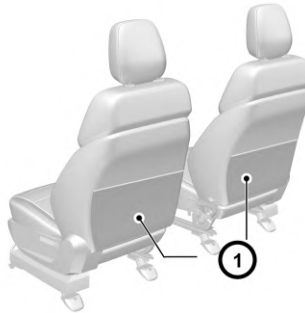

The seat pocket is located behind the front seat backrest.

### Floor Console Storage

#### Console Storage Box (if equipped)

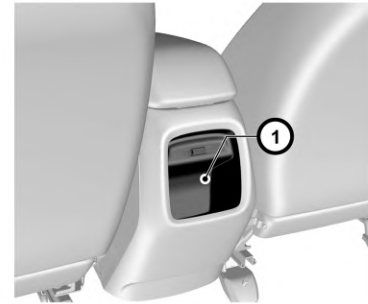

Some vehicle models have the storage box at the rear of the console.

### Armrest Storage Box (if equipped)

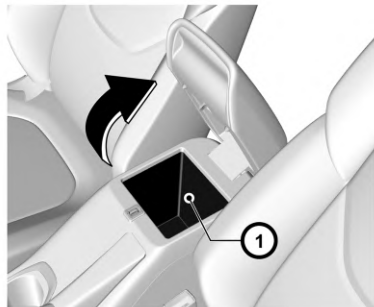

If equipped, lift the front of the storage box cover to open the box. Close the storage box cover when closing.

### Luggage/Load Locations

#### Luggage Compartment

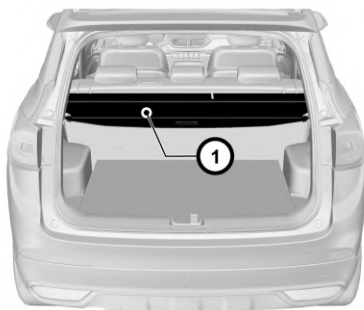

The cover is used to shield the objects in the luggage compartment.

### Packing Up Luggage Cover

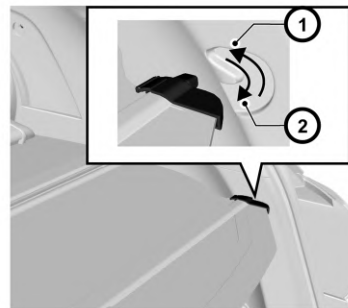

As shown in the figure, release the luggage cover plates from the guide slots on both sides of the luggage compartment 1, and the cover will retract automatically.

To deploy the luggage cover, pull the luggage cover from the recoiler, and clamp the two ends of cover plate into the guide slots on both sides of the luggage compartment 2.

## Luggage Cover Removal

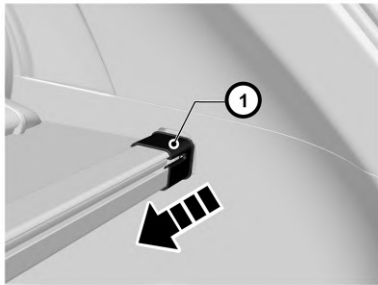

As shown in the figure, press the caps on both ends of the luggage cover recoiler toward the middle to remove the luggage cover from the vehicle.

To install the cover, press the caps on both ends toward the middle, and align the caps to the slots and then release the caps to fix the recoiler in the slots.

### Warning

Do not store heavy or sharp objects on the luggage compartment cargo cover. The luggage cover cannot bear loads. In a crash, these objects may cause the cover to open and could result in injury.

Do not place any object on the luggage compartment cargo cover. On one hand, the luggage cover cannot bear loads; on the other hand, the object may hurt occupants under emergencies.

## Additional Storage Features

### Shopping Bag Hooks

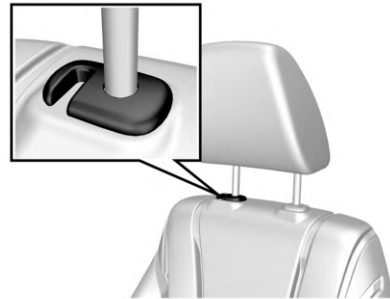

The headrest is equipped with a hook to hang a shopping bag or purse from.

### Roof Rack System

The roof rack is an external trim item. To avoid damaging the vehicle, please do not use the rack to carry anything.

## Information on Loading the Vehicle

- The heavy objects inside the luggage compartment should be placed close to the backrest. Make sure that the backrest is fastened. If objects need to be piled in layers, heavy ones should be placed in the bottom.
- Objects scattered in the luggage compartment should be fixed to prevent them from sliding.
- The loaded object(s) should not be higher than the upper edge of the backrest.
- Object should not be placed on the luggage cover or the instrument panel. Do not cover the air bag or other parts on the instrument panel.
- The objects loaded should neither hinder the operation of pedals, parking brake, and shift lever nor limit the free movement of the driver. Do not put any object not fixed in the vehicle.
- Do not drive the vehicle with the liftgate open. It is forbidden to place a cigarette lighter, propane gas cylinder, perfume, or other combustible/explosive materials in

the vehicle. These articles may cause a fire or explode when the vehicle is under high temperature for a long time.

Avoid replacing a cigarette lighter, propane gas cylinder or other combustible/explosive materials in the vehicle. These articles may be on fire and/or explode when the vehicle is under high temperature for a long time.

# Instruments and Controls

## Instrument Panel Overview

Instrument Panel Overview .....	48
---------------------------------	----

## Controls

Steering Wheel Adjustment .....	49
Steering Wheel Controls .....	49
Horn .....	50
Windshield Wiper/Washer .....	50
Rear Window Wiper/Washer .....	51
Clock .....	52
Power Outlets .....	52
Ashtrays (If Equipped) .....	53

## Warning Lights, Gauges, and Indicators

Instrument Cluster .....	54
Speedometer .....	55
Odometer .....	56
Tachometer .....	56
Fuel Gauge .....	57
Engine Coolant Temperature Gauge .....	57
Turn Signal .....	57
Seat Belt Reminders .....	58
Airbag Readiness Light .....	59
Charging System Light .....	60
Malfunction Indicator Lamp .....	60
Brake System Warning Light .....	61

Antilock Brake System (ABS) Warning Light .....	62
Power Steering Warning Light .....	63
StabiliTrak OFF Light .....	63
Traction Control System (TCS)/ StabiliTrak Light .....	64
Engine Coolant Temperature Warning Light .....	64
Tire Pressure Light .....	65
Engine Oil Pressure Light .....	65
Low Fuel Warning Light .....	66
Security Light .....	66
High-Beam On Light .....	67
Rear Fog Lamp Light .....	67
Lamps On Reminder .....	67
Cruise Control Light .....	68
Door Ajar Light .....	68

## Information Displays

Driver Information Center (DIC) .....	69
---------------------------------------	----



## Instrument Panel Overview

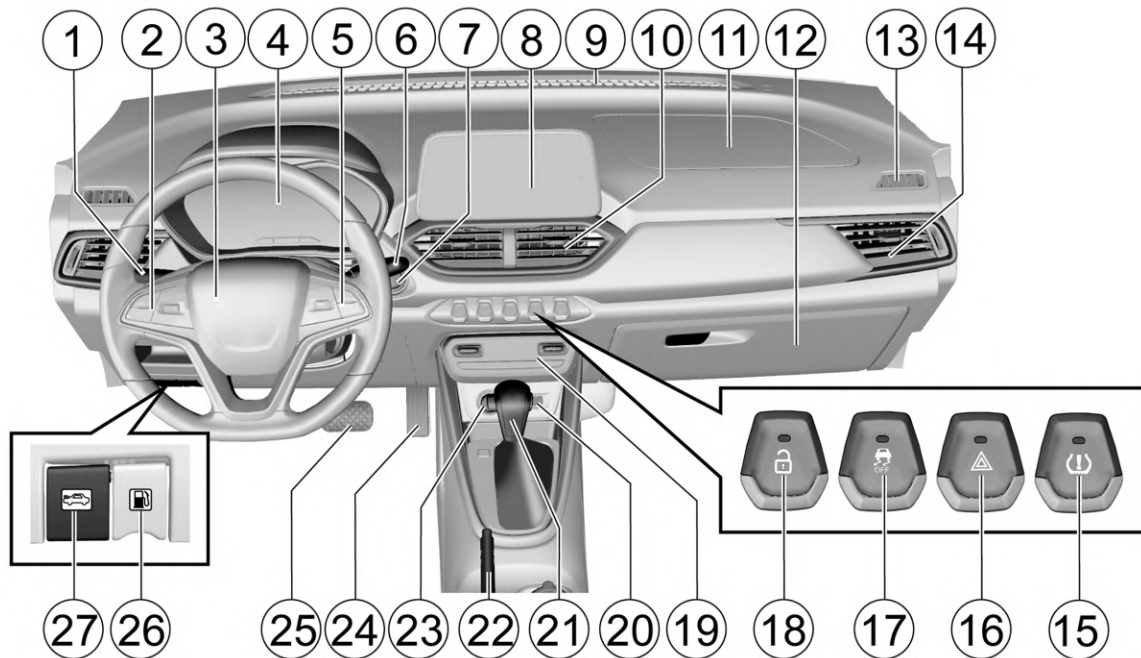

1. Vehicle Lamp and Turn Signal Lamp Switch

2. Cruise Control System Control Button  
(If Equipped)

3. Airbag - Driver/Horn Switch

4. Instrument Cluster
5. Audio System Control Button (If Equipped)
6. Wiper and Washer Switch
7. ENGINE START STOP Button (If Equipped)
8. Vehicle Audio
9. Front Air Outlet
10. Central Air Outlet
11. Front Airbag - Passenger (If Equipped)
12. Glove Box
13. Defrost Air Outlet For Front
14. Side Air Outlet
15. TPMS Reset Button (Indirect TPMS)
16. Hazard Lamps Switch
17. ESC OFF Switch (If Equipped)
18. Central Door Lock Switch
19. A/C Control Panel
20. Accessory USB Power Outlet
21. Shift Lever/Knob
22. Parking Brake Lever
23. 12V Power Outlet
24. Accelerator Pedal

25. Brake Pedal
26. Fuel Filler Cap Release Lever
27. Hood Release Lever

## Controls

### Steering Wheel Adjustment

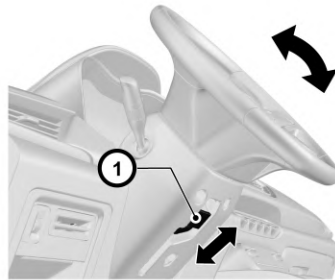

According to the configuration, the steering wheel angle of some vehicle models can be adjusted up and down. It is only allowed to adjust the steering wheel after the vehicle has fully stopped.

If you need to adjust the steering wheel:

1. As shown in the figure, push the adjustment lever under the steering wheel downwards;

2. Adjust the steering wheel to the desired position and then pull back the adjustment lever to lock the steering wheel;
3. Check and confirm that the steering wheel has been locked firmly.

The driver must keep absolute control of the steering wheel during driving. Do not adjust the steering wheel while driving the vehicle. Adjusting the steering wheel during driving can cause the vehicle out of control.

### Steering Wheel Controls

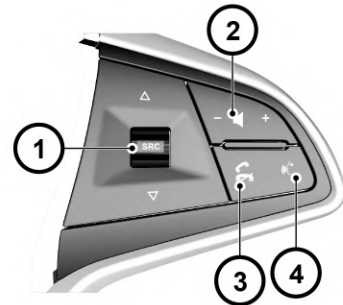

1. **Sound Source Selection/Seeking and Selecting Music**

Press the button to switch the Radio/USB/Bluetooth (if equipped) source; move up and down to find and select music.

### 2. Volume Adjustment Thumbwheel

Press the left and right ends of the change button to increase or decrease the volume.

### 3. Answer/Hang Up Button

Short press this button to enter the Bluetooth interface of the audio system. After the Bluetooth connection is made to the phone and audio system, you can press this button to answer/hang up the call. Refer to the Manual of Audio System for details.

### 4. Voice Pass Thru (if equipped)

If equipped with Apple Carplay or Android Auto, a long press to enter voice control screen and connected to Apple Carplay or Android Auto.

## Horn

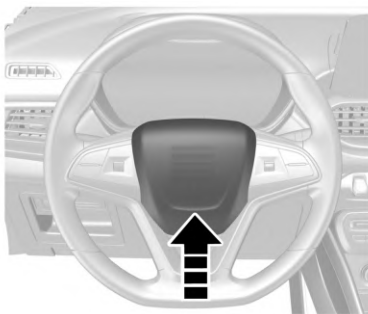

Press the steering wheel to blow the horn.

## Windshield Wiper/Washer

### Front Windshield Wiper and Washer

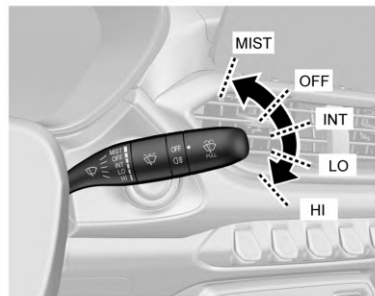

To use the front windshield wiper, turn on the ignition first and then push down the windshield wiper/washer lever. The front windshield wiper has the following five working positions:

**OFF:** Turn the system off.

**INT:** Intermittent operation

**Lo:** Continuously wipe at low speed

**Hi:** Continuously wipe at high speed

**MIST:** Lift the lever up in OFF position and release it to wipe once.

Depending on vehicle model, some vehicles can adjust the wiping speed in the intermittent operation. Turn the windshield wiper lever to select the appropriate wiping speed.



To spray cleaning fluid on the windshield:

- Turn the ignition to “ON (connected)” position;
- Pull the windshield wiper/washer lever toward the steering wheel, and the spray pump immediately sprays water to the front windshield; release the front wash and it stops spraying;
- When the lever is released, additional wipes may occur depending on how long the windshield washer had been activated.

Do not operate the windshield washer for more than 10 seconds or operate when the wash tank is empty. Or the washer motor will be overheated, which may result in expensive repair costs.

### Warning

In cold weather, to avoid the wipers from getting frozen, spray warm water on the frozen area to de-ice and then wipe off the water immediately to prevent further icing.

Blurred vision of the driver can lead to a crash and may cause personal injuries and damage to the vehicle or other properties.

## Rear Window Wiper/Washer

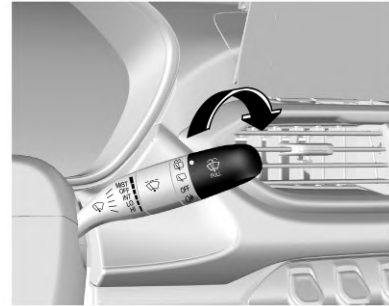

To use the rear windshield washer, turn the ignition to “ON” position first and then turn the rear wiper and washer switch knob to .

Turn the rear wiper and washer switch knob to  position. The rear water pump immediately sprays water to the rear window, and stops spraying when releasing the knob.

During reversing, if the front wiper is working and the liftgate is closed, the rear wiper will run once even if its switch is not turned on.

## Clock

The clock is located on the display of audio system. See **Vehicle Audio System Instructions** for time setting.

## Power Outlets

### Front Accessory USB Power Outlet

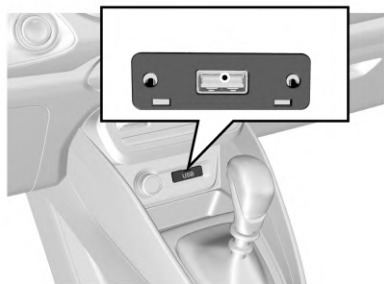

The USB outlet of the front accessory power supply is located below the middle of the dashboard.

This USB interface can be used to charge mobile phones. The interface of models with low-level configuration can only be used for charging,

but the one in high-level configuration models can also be connected to a USB flash drive to read audio files.

The charging power outlet is unavailable if the ignition is turned off.

For details on USB interface, refer to the instructions of audio system.

### Rear Accessory Power Outlet (5V) (if equipped)



If the vehicle is equipped with rear accessory USB power outlet (5V), it is located at the rear of the console. It can be used for charging mobile phones, with a maximum charging current of 1A. The power outlet is unavailable if the ignition is turned off.

### 12V Power Outlet (if equipped)



12V power outlet is located at the front of the console, under the A/C control panel. The power outlet is not available if the ignition is turned off.

## Ashtrays (If Equipped)

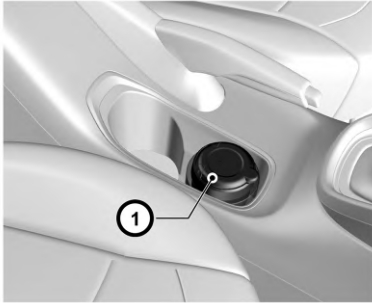

It is located on the console in the middle of the front seats, the ashtray containers can be moved inside the vehicle. Open its cover for use.

The ashtray can only be used for containing cigarette ash not combustible rubbish.

## Warning Lights, Gauges, and Indicators

### Instrument Cluster

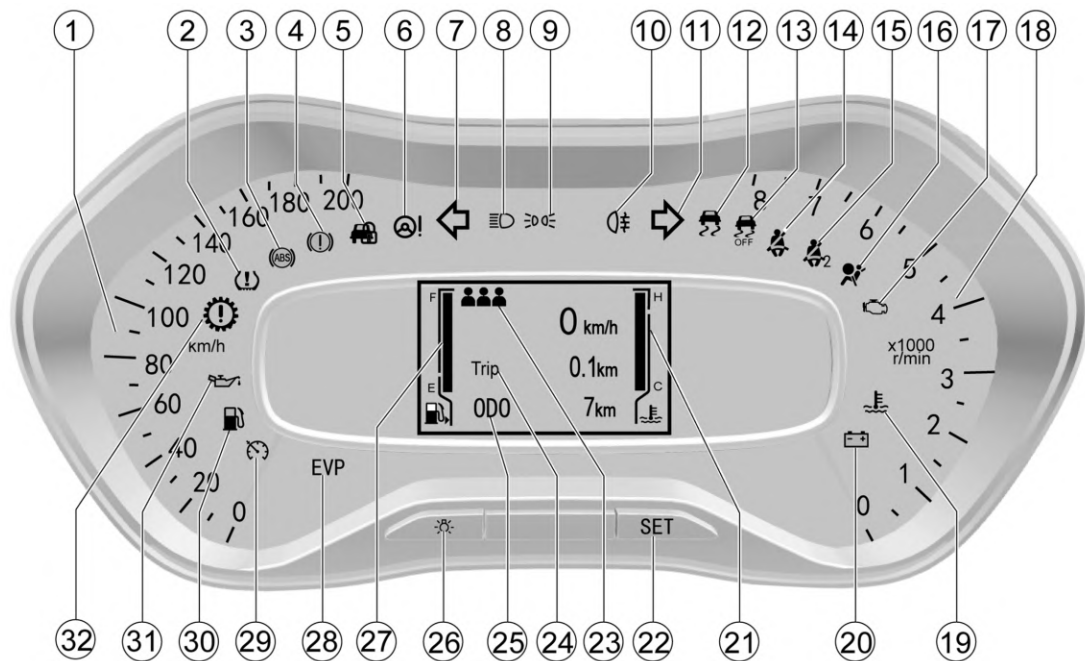

1. Speedometer
2. Tire Pressure Monitor System (TPMS) Fault Indicator (if equipped)
3. Warning Lamp of Anti-Lock Brake System (ABS)
4. Brake System/Hand Brake Indicator/EBD Warning Lamp
5. Engine Immobilizer System Indicator
6. Electronic Power Steering (EPS) Warning Lamp
7. Left Turn Signal Lamp/Hazard Warning Indicator
8. Headlamp High Beam Indicator
9. Position Lamp Indicator
10. Rear Fog Lamp Indicator
11. Right Turn Signal Lamp/Hazard Warning Indicator
12. Electronic Stability Control (ESC) Fault Warning Lamp (if equipped)
13. Electronic Stability Control (ESC) Off Indicator (if equipped)
14. Driver Fasten-Seat-Belt Warning Lamp
15. Front Passenger Fasten-Seat-Belt Warning Lamp (if equipped)
16. Airbag Warning Lamp
17. Engine MIL
18. Engine Tachometer
19. Coolant Temperature Too High Warning Lamp
20. Charging System Warning Lamp
21. Water-Thermometer
22. Setting Button
23. Rear Seat Fasten Seat Belt Warning Lamp
24. Trip Computer Display Screen (if equipped)
25. General Odometer
26. Brightness Adjustment Button
27. Fuel Gauge
28. EVP Warning Light (if equipped)
29. Cruise Control System Working Condition Indicator (if equipped)
30. Fuel Level Too Low Warning Lamp
31. Oil Pressure Low Warning Lamp

32. Transmission Fault Warning Lamp, (for auto-transmission only)

After the ignition is turned on, as a functional test, most of the control indicators will illuminate for a short while.

Colors of the control indicators mean:

**Red:** Danger, important reminder

**Yellow:** Warning, information, fault

**Green:** Activation confirmed

**Blue:** Activation confirmed

## Speedometer



It displays the vehicle speed.



Keep the speed within the limit when driving in a speed limit zone.

## Odometer

### General Odometer

ODO

7km

It displays the total accumulated kilometers of the vehicle.

It is lawfully forbidden to adjust the odometer.

### Subtotal Odometer

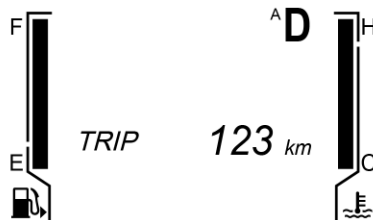

It shows vehicle kilometers for a driving trip after it has been reset to zero. In this mode, long press the adjustment lever to clear the trip distance.

### Tachometer



It displays the engine crankshaft revolutions per minute.

## Fuel Gauge

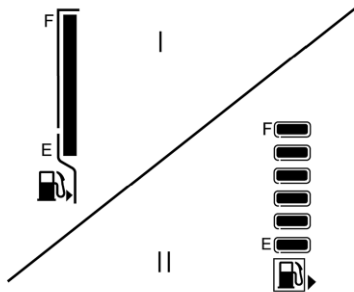

It displays the fuel level in the fuel tank.

E: Empty

F: Full

If the fuel level in the fuel tank is too low, the control indicator will illuminate. Add fuel immediately. It is strictly prohibited to use up the fuel in the fuel tank!

As some fuel remains in the fuel tank, the adding amount can be less than the fuel tank capacity. During braking, acceleration or cornering, as the fuel in the fuel tank shakes, indication on the fuel gauge fluctuates.

Before adding fuel, stop the vehicle and shut down the engine.

## Engine Coolant Temperature Gauge

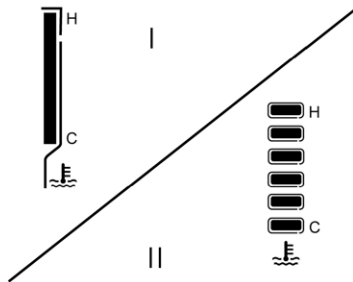

It displays the temperature of the engine coolant.

C: Cold State

H: High Temperature

When the water temperature gauge indicates that it reaches or close to "H" area, it means that the engine is overheated. The engine should be shut down immediately for inspection.

If the engine coolant temperature is too high, stop the vehicle, shut down the engine and inspect the coolant level.

## Turn Signal



The turn signal lamp/hazard warning lamp indicator is used to confirm whether the outside turn signal lamp/hazard flasher can work normally. If you find that the green arrow does not flash as you send a turn signal or press the hazard warning button, inspect the fuse and bulb and if necessary, replace them.

**⚠ Danger**

If a turn signal lamp or hazard flasher indicator bulb has burnt out, replace it immediately. These indicators are essential for assurance of driving safety. Failure to keep these indicators in working condition may cause a crash, resulting in personal injuries or even death, and damage to the vehicle or other properties.

If the flashing time is shorter than normal, it indicates that the turn signal lamp bulb has burnt out and must be replaced.

**Seat Belt Reminders**

The seat belt warning lamp illuminates if the driver does not fasten the seat belt properly after the ignition is turned on. Following this, the following circumstances will appear unless the driver fastens the seat belt properly:

- The seat belt warning lamp turns on.
- If the vehicle speed exceeds 20 km/h, the warning lamp will flash and the warning buzzer will buzz for a certain time.

**Front Passenger Fasten-Seat-Belt Warning Lamp (if equipped)**

The seat belt warning lamp illuminates if the front passenger seat is occupied but the occupant does not fasten the seat belt properly after the ignition is turned on. Following this, the following circumstances will appear unless the front passenger fastens the seat belt properly:

- The seat belt warning lamp turns on.
- If the vehicle speed exceeds 20 km/h, the warning lamp will flash and the warning buzzer will buzz for a certain time.

This warning lamp does not illuminate if the front passenger side seat is not occupied after the ignition is turned on.

### Rear Passenger Fasten Seat Belt Warning Lamp (if equipped)



The seat belt warning lamp illuminates if the rear seat is occupied but the occupant does not fasten the seat belt properly after the ignition is turned on.

The following circumstances will appear unless the rear seat passengers fasten the seat belt properly:

- The seat belt warning lamp turns on (“3”/“4”/“5” which the lamp indicates the position of left, middle, right of the rear seat).
- If the vehicle speed exceeds 20 km/h, the warning lamp will flash and the warning buzzer will buzz for a certain time.

This warning lamp does not illuminate if the rear seats are not occupied or the warning function is deactivated (deactivate the warning function by IP cluster setting only valid for one loop), after the ignition is turned on.

#### Note

Do not deactivate the rear passenger fasten seat belt warning lamp when passengers are seated in the rear seats. This warning ensures that the rear seat passenger is belted in properly.

## Airbag Readiness Light



The airbag warning lamp illuminates when the ignition is turned on and it goes out several seconds later. This indicates that both the warning lamp bulb and the airbag system can work normally.

In case of an airbag fault, the warning lamp will give out indication in any of the following ways:

- The lamp does not illuminate when the ignition is turned on.
- The lamp does not go out after it illuminates.
- Flashing or normally on during driving.

**⚠ Danger**

If the airbag warning lamp flashes or stays illuminated during driving, it indicates an airbag system fault. The airbag system will get deactivated and thus fail to trigger off in a crash. We strongly advise you to drive the vehicle to the nearest dealer for inspection. If a crash happens after the airbag system fault has occurred, personal injuries or even death can occur.

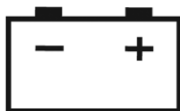
**Charging System Light**

This warning lamp illuminates as you turn on the ignition. It goes out as the engine is started.

If the charging system warning lamp illuminates during driving:

1. Drive the vehicle off the lane in a safe manner.
2. Stop
3. Check and confirm that the drive belt has not loosened or broken.
4. If the drive belt is normal but the charging system warning lamp stays illuminated, it can indicate a charging system fault. See your dealer.

**Caution**

The charging system warning lamp indicates there may be a problem with the charging system.

Do not drive your vehicle when the charging system warning lamp is on.

Driving your vehicle while its charging system is malfunctioning can cause damage to the vehicle.

If you often drive the vehicle for short trips, the battery capacity consumes more quickly, so it is necessary to replenish the electric energy by charging the battery or having a long trip.

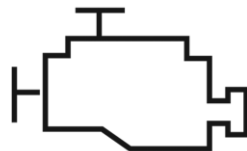
**Malfunction Indicator Lamp**

This indicator lamp illuminates when the ignition is turned on but the engine has not started. This indicates that the indicator lamp bulb can work normally. The lamp goes out after the engine is started. This malfunction indicator lamp (MIL) illuminates upon occurrence of any component or subsystem fault related to the emission system. Once the electronic control module (ECM) detects any fault, the malfunction indicator lamp will keep illuminated. In case that serious misfire is detected, the malfunction indicator lamp will flash constantly. Serious misfire can cause damage to the catalytic converter. In case of this, the electronic system of the vehicle will

switch to an emergency running procedure so that you can continue the trip. However, we advise you to go to the nearest Dealer for fault removal as soon as possible. If MIL illuminates for a while and then goes out, it is normal, not indicating any system fault.

### Caution

If the Engine Malfunction Indicator Lamp (MIL) illuminates, it indicates that a fault exists. Continuous driving after the MIL has illuminated can cause damage to the emission control system, thus reducing fuel economy and vehicle controllability. See the nearest dealer for vehicle repair as soon as possible.

## Brake System Warning Light



The brake system warning lamp illuminates after the ignition is turned on and it goes out several seconds later (if the parking brake has been released). This indicates that the warning lamp can work normally.

The brake system/EBD warning lamp also illuminates when the parking brake engages. The lamp goes out after the parking brake is released. Fully release the parking brake before starting the vehicle.

If the brake system warning lamp illuminates after the parking brake is fully released, it indicates that the brake fluid level in the fluid reservoir is too low or an EBD system fault has occurred.

Do the following:

1. Carefully drive the vehicle off the lane and then stop the vehicle.
2. Check the brake fluid level.
3. Add the recommended brake fluid until the fluid level reaches MAX (highest) mark. Refer to “Adding Brake/Clutch Fluid”.
4. For the following circumstances, drive the vehicle at a safe speed to the nearest dealer to inspect the brakes and confirm that the brake system is working normally.
5. For the following circumstances, tow the vehicle to the nearest dealer for inspection and repair:
  - You discovered brake system leakage.
  - The brake system warning lamp keeps illuminated.
  - The brake cannot work normally.

**Caution**

Do not drive with the brake system warning lamp on.

- This may mean your brakes are not working properly.
- Driving with malfunctioning brakes can lead to a crash resulting in personal injuries and damage to your vehicle and other property.

 **Warning**

If the brake system warning lamp does not illuminate after the parking brake engages with the ignition switch turned on, do not drive the vehicle.

Ensure that the LED of the warning lamp works normally. If the lamp does not illuminate when the parking brake engages with the ignition switch turned on, even though the LED of the warning lamp works normally, still go to the nearest dealer to inspect the brake system.

This may indicate a brake system fault.

(Continued)

**Warning (Continued)**

Failure to keep the brake system in proper working condition could result in a crash which could cause personal injuries, and damage to the vehicle or other properties.

### Antilock Brake System (ABS) Warning Light



The ABS warning lamp will illuminate immediately the ignition is turned on. It indicates that the system is conducting self-

inspection and the warning lamp bulb can work normally. The warning lamp goes out several seconds later.

If the ABS warning lamp does the following, see your dealer.

- Not illuminated as the ignition is turned on
- Always illuminated
- Illuminated during driving

If the ABS warning lamp illuminates during driving, it indicates possibility of an ABS fault.

Though the vehicle can run normally without ABS, see your dealer for an ABS inspection and necessary repairs.

## Power Steering Warning Light



This warning lamp will illuminate immediately the ignition is turned on. It indicates that the system is conducting self-inspection and the warning lamp bulb can work normally. The warning lamp goes out several seconds later.

When the Electronic Power Steering (EPS) system detects a fault, the warning lamp will give an indication. The vehicle can still steer even if the steering system has a fault, but it demands much greater effort. In case of the following, see your dealer.

- The lamp does not illuminate when the ignition is turned on.

- The lamp does not go out after it illuminates.
- The lamp illuminates during driving.

### Caution

Do not drive the vehicle when the power steering warning lamp illuminates.

The warning lamp illuminating during driving may mean that the Power Steering column is not working properly.

Driving with this malfunction may lead to a crash resulting in personal injuries and damage to your vehicle and other property.

## StabiliTrak OFF Light



The warning lamp illuminates after the ignition is turned on and it goes out several seconds later. This indicates that the warning lamp can work normally.

If you press “ESC OFF” switch when the vehicle speed has not exceeded the threshold value, certain functions of ESC will be deactivated.

At this time, ESC OFF indicator illuminates.

See *Electronic Stability Control (ESC)* ⇨ 121

Generally, it is not advised to turn ESC OFF switch off.



## Traction Control System (TCS)/ StabiliTrak Light



The warning lamp illuminates after the ignition is turned on and it goes out several seconds later. This indicates that the warning light is working normally.

The ESC lamp flashes once when the ESC function is active. This informs the driver that ESC is working.

If the ESC lamp stays illuminated, it indicates an ESC fault.

See *Electronic Stability Control (ESC)* ⇨ 121

## Engine Coolant Temperature Warning Light



The engine coolant temperature warning light illuminates as you turn on the ignition, and it goes out several seconds later. It indicates that both the system and the indicator bulb are working normally.

This indicator illuminates when the coolant temperature is too high. It indicates that the engine has overheated. Do not continue driving the vehicle.

## EVAP Warning Light (if equipped)

# EVAP

The EVAP warning light illuminates after the ignition is turned on and goes out several seconds later. This indicates that the EVAP warning light can work normally.

For vehicle equipped with EVP (electrical vacuum pump for brake assistant), if the EVP warning light illuminates in below ways, it indicates the EVP fault has occurred:

- EVP light does not illuminate when ignition turns on;
- EVP light keeps illuminating and doesn't go off after several seconds of ignition turning on;
- EVP light flashes when driving;

- EVP light illuminates when driving;

When EVP fault occurs, it will be less brake vacuum assistant, and you will feel the brake pedal is hard to press down or need more force to press down. If EVP fault is confirmed, must drive very carefully in low and safe speed, and see your dealer as soon as possible. If you are not sure if the car is safe to drive, call your dealer for assistant.

### Warning

If EVP warning light illuminates when driving, have your car inspected by nearest dealer as soon as possible otherwise, it is at high risk of causing an accident due to brake control reduction.

## Tire Pressure Light



The warning lamp illuminates after the ignition is turned on and it goes out several seconds later. This indicates that the warning lamp can work normally.

The TPMS fault indicator illuminates when the tire pressure is too low or too high, or when a TPMS fault occurs.

For the correct tire pressures, see *Tire Pressure*  
↪ 146

## Engine Oil Pressure Light

### Engine Oil Pressure Too Low Warning Lamp



As you turn on the ignition, the engine oil pressure too low warning lamp illuminates and it goes out after the engine gets started. This indicates that the indicator lamp bulb can work normally.

If this warning lamp illuminates while the engine is running, it indicates that the engine oil pressure may have dropped to a dangerous level. Stop the engine and check the oil level immediately.

If the oil level is too low, add the specified engine oil to the appropriate level. See *Engine Oil* ⇨ 131 in Vehicle Maintenance.

If the oil level is normal, see your dealer to check the lubrication system.

### Caution

Your engine oil pressure may be dangerously low.

Do not drive with the engine oil pressure warning lamp on.

Driving your vehicle with low oil pressure can result in costly damage to your vehicle.

## Low Fuel Warning Light



This warning lamp will illuminate immediately the ignition is turned on. It indicates that the system is conducting self-inspection and the warning lamp bulb can work normally. If this lamp keeps illuminated after the ignition is turned on or it illuminates during driving, it indicates that the fuel amount in the fuel tank is insufficient and you should replenish the fuel in time.

Do not exhaust the fuel, otherwise the catalytic converter can be damaged.

## Security Light



This indicator illuminates when the door is opened. It goes out after the engine is started. This indicates that the indicator can work normally.

See *Engine Starter Protection* ⇨ 114

### High-Beam On Light

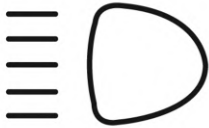

The high beam indicator illuminates when the headlamp high beam is turned on.

### Rear Fog Lamp Light

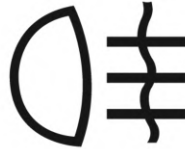

This indicator illuminates when the rear fog lamp is turned on. See *Rear Fog Lamps* ↪ 75

### Lamps On Reminder



This indicator illuminates when the position lamp is turned on.

## Cruise Control Light



This indicator illuminates when the cruise control function is activated.

See *Cruise Control* ⇨ 122

## Door Ajar Light

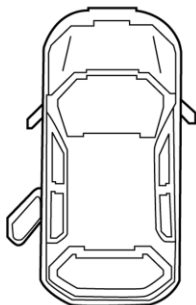

If any door in the front or rear row is ajar or not fully closed, a warning lamp shaped like the door ajar will illuminate; if the liftgate is ajar or not fully closed, a warning lamp shaped like a liftgate ajar will flash.

## Instrument Cluster Display Brightness Adjustment (if equipped)



Press the brightness adjustment button  of the combination instrument to switch to the brightness adjustment interface. At this time, each press of the button increases the brightness of one grid. After selecting the appropriate brightness, if there is no action within about three seconds, the adjustment is completed and it will returned to the previous interface.

The low-level configuration vehicle does not display the above interface. Directly press the adjustment button to adjust the brightness.

## Information Displays

### Driver Information Center (DIC)

Trip Computer Display Screen  
(if equipped)

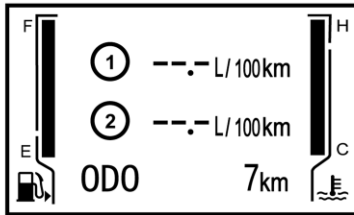

The trip computer display screen is located between the tachometer and the speedometer. It can display fuel gauge, engine coolant temperature gauge, general odometer, small odometer, tire pressure, fuel range, instantaneous fuel consumption, average fuel consumption, etc., depending on the vehicle configuration.

### Tire Pressure Indication (if equipped)

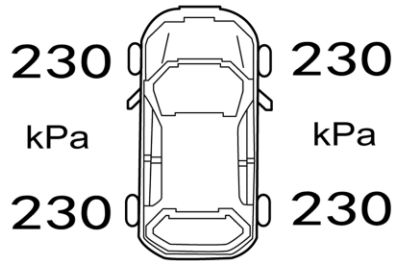

It shows the air pressure of each tire monitored by the Tire Pressure Monitoring System (TPMS) in bar.

When the tire pressure is too low or too high, the corresponding tire pressure value flashes. Adjust the tire pressure.

For the standard tire pressures, see *Vehicle Data* ⇨ 166.

### Caution

Keep the tire pressure within the reference range, otherwise the tire service life and vehicle controllability can be reduced, or flat tire can happen which is very dangerous.

### Indirect Tire Pressure Monitor System Reset (if equipped)

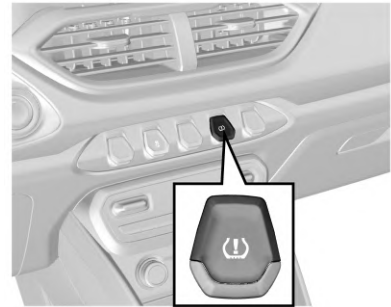

For vehicle equipped with indirect TPMS (tire pressure monitoring system), must reset TPMS after tire replacement or tire pressure inflation adjustment, steps as:

1. Inflate all four tires to standard tire pressure, see vehicle parameter.
2. Press the reset button  (if equipped) on the instrument panel for two seconds to reset the indirect TPMS.
3. The cluster shows “Tire pressure reset succeed” indicates the indirect TPMS successfully reset.

**Note**

- When first time using the car, it is suggested to do TPMS reset as above.
- Must inflate all four tires to standard pressure before reset TPMS.
- This TPMS reset is only needed for indirect TPMS, direct TPMS does not need TPMS reset and have no reset button.

**Fuel Range Meter (if equipped)**

RANGE

88 km

It indicates the reference mileage the vehicle can continuously run for with the current remaining fuel amount. It changes as the fuel consumption under the current driving condition changes.

Fuel range is for reference only. Add fuel as soon as possible the fuel level low indicator illuminates.

**Display of Gear of Automatic Transmission (if equipped)**

For automatic transmission models, the gear information is also displayed. See the automatic transmission part of the Driving and Control Chapter for details.

**Instantaneous Fuel Consumption Meter (if equipped)**

INST.FE

7.5 L/100km

It indicates the reference fuel consumption (in L/100 km) in the current accelerator control state and under the current driving cycle.

**Driving cycle:** The period from starting the engine to shutting it down represents a driving cycle.

The instantaneous fuel consumption changes real-time as the throttle valve opening, revolution speed and vehicle load change.

### Average Fuel Consumption Meter (if equipped)

AVG.FE

7.0 L/100km

It indicates the average fuel consumption given for reference by the driver in the current driving mode, under the current driving cycle.

Average fuel consumption can help the driver develop a good driving habit and it indicates in L/100 km.

In different driving modes, the reference average fuel consumption is different.

Driving mode: driving conditions such as driving in urban area, high-speed driving, driving at different constant speeds, acceleration/deceleration condition, driving at the same speed and with different gears engaged, etc.

### Adjustment Button

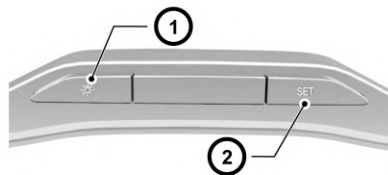

### Setting button

Short press or long press the setting button to switch the display or perform a clear operation.

This button for low-level configuration vehicle only performs subtotal mileage clearing.

Long press means press for more than 2 seconds and short press means press for 2 seconds or less.

For more details, see Display Screen Mode Switch.



**Brightness adjustment button**

Press the brightness adjustment button to adjust the displaying brightness of combination instrument.

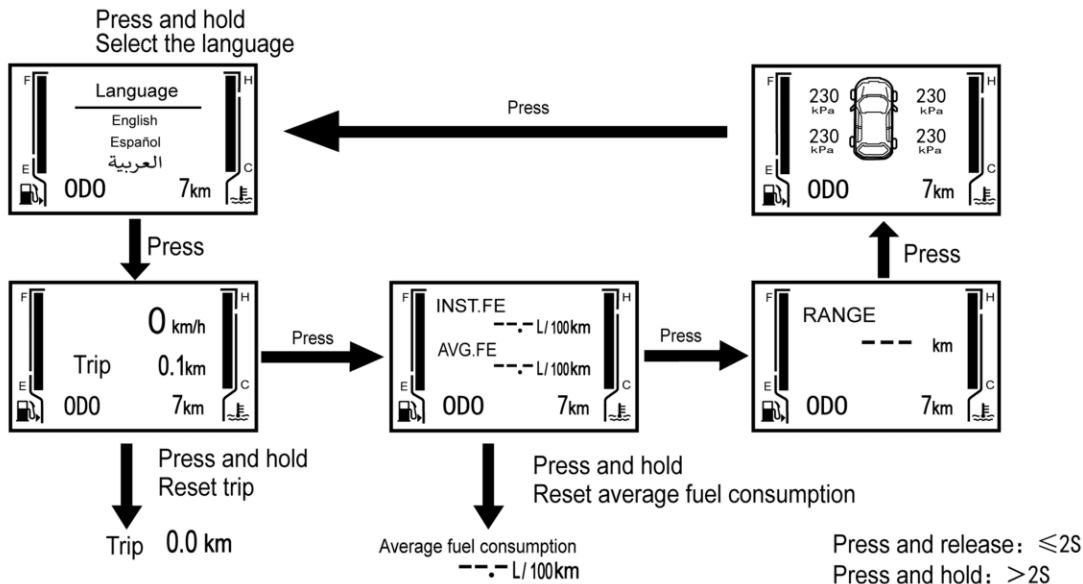

## Lighting

### Exterior Lighting

Exterior Lamp Controls .....	73
Daytime Running Lamps (DRL) .....	74
Hazard Warning Flashers .....	74
Turn and Lane-Change Signals .....	75
Rear Fog Lamps .....	75
Driving Lamps .....	75

### Interior Lighting

Load Compartment Lamps .....	75
Reading Lamps .....	76

## Exterior Lighting

### Exterior Lamp Controls



To switch on or off the headlamp, tail lamp and parking lamp, turn the end of the combination switch control lever.

The lighting switch has three positions and they represent different lighting functions:

**OFF** : All the lamps are turned off.

 : Dashboard lamp, position lamp indicator, parking lamp and license plate lamp illuminate.

 : The low beam and all the above lamps illuminate (the ignition must be in the ON position).

### High Beam



To turn on high beam headlamp:

- Ensure that the ignition is in ON;
- The headlamp is in a low beam state;
- Push the combination switch control lever towards the instrument panel.

The headlamp high beam indicator illuminates when the headlamp high beam is turned on.

To switch from headlamp high beam to low beam, pull the control lever towards the opposite direction until it returns to the normal position.

When approaching an on-coming vehicle or the vehicle ahead, switch from high beam to low beam. High-beam headlamps beam can make other drivers feel temporarily blind and cause a crash.

### Headlight Flashing

To activate headlamp high beam flashing, pull the combination switch control lever toward yourself and then release it.

The control lever will return to the normal position as you release it.

Before you release the control lever, the high beam headlamp keeps illuminated.

### Headlamp OFF Delay

To trigger the headlamp OFF delay function, turn off the headlamp and pull the light control lever for one second. Pull the light control lever twice after you shut down the engine and turn the ignition to ACC or LOCK position, or after you pull out the key. After remote locking, the low beam lamp will turn off after 30 seconds; if the vehicle is not remotely locked, the low beam lamp will turn off after 10 minutes.

### Lamp ON Reminder (if equipped)

If any lamp switch is not turned to OFF position after you turn the ignition to LOCK position or pull out the key, the buzzer will send out alarm sound as the driver's door is opened. The alarm sound stops after the lamp is turned off.

Do not replace with a high-power bulb (for example, retrofit with a xenon headlamp) in case the lamp burns out or an accident arises from it.

### Daytime Running Lamps (DRL)

The day running lamp turns on automatically as the engine starts; it goes out automatically as the clearance lamp is turned on. The daytime running lamp and position lamp are in the same lamp housing.

### Hazard Warning Flashers

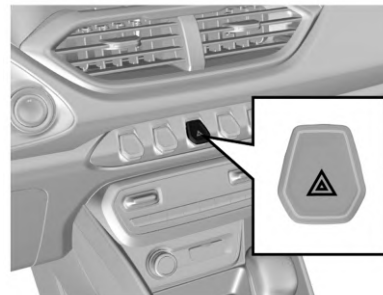

Press  to turn on/off the hazard flasher.

## Turn and Lane-Change Signals

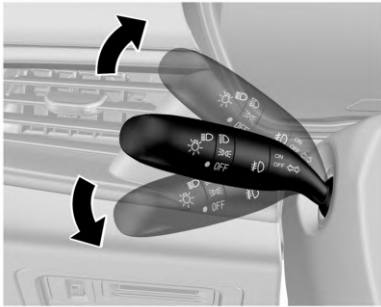

Control lever upward = right turn signal lamp  
Control lever downward = left turn signal lamp  
After cornering, the turn signal interrupts automatically and the control lever returns to the normal position.

To change the lane, you can pull the control lever to halfway position (not reaching the turn signal lamp position) and keep pulling it. After lane change, release the control lever and it will return to the normal position automatically.

## Rear Fog Lamps



When the headlamp is in low beam or the front fog lamp is turned on, turn the rear fog lamp control knob to  position and then release it to turn on the rear fog lamp. Turn the knob again to turn off the rear fog lamp.

If the low beam lamp or front fog lamp is turned off with the rear fog lamp turned on, the rear fog lamp keeps on.

## Driving Lamps

### Reversing lamps

The backup lamp illuminates after you turn on the ignition and shift to reverse gear.

## Brake Lamp

The stop lamp illuminates as you depress the brake pedal.

## Interior Lighting

### Load Compartment Lamps

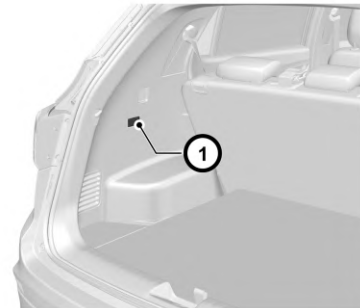

The luggage compartment illumination lamp illuminates as the liftgate is opened. It goes out after the liftgate is closed.

## Reading Lamps

### Front Reading Lamp

#### Type-I



The lamp has three working positions:

○: Off-position. The lamp does not illuminate even a door is opened.

DOOR (Middle position): Illuminates when any door is opened. After closing all the doors, including the liftgate, the reading lamp is gradually turned off. When the ignition is turned off and the door is unlocked, it will illuminate for a while.

☹: On-position. The lamp illuminates and keeps illuminated until it is manually turned off.

#### Type-II

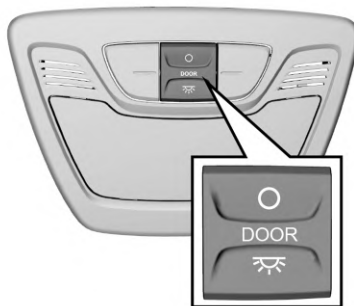

The lamp has three working positions:

○: Off-position. The lamp does not illuminate even a door is opened.

DOOR (Middle position): Illuminates when any door is opened. After closing all the doors, including the liftgate, the reading lamp is gradually turned off. When the ignition is turned off and the door is unlocked, it will illuminate for a while.

☹: On-position. The lamp illuminates and keeps illuminated until it is manually turned off.

### Warning

Do not use the interior lamps when driving in the dark.

A bright passenger compartment can reduce the visibility outside and may cause a crash.

### Rear Reading Lamp\*



The rear reading lamp has two working buttons:

☒: Press the button. The lamp turns on. It will not turn off until the button is pressed again.

☒: The lamp gradually illuminates if the switch is pressed and any door is opened; it works for a while and then gradually goes out after all the doors, including the liftgate, are closed.

## Infotainment System

### Introduction

Overview ..... 78

### Radio

AM-FM Radio .....81

### Audio Players

USB .....81

Bluetooth Audio ..... 82

### Phone

Bluetooth ..... 82

Apple CarPlay and Android Auto ..... 83

Pairing a Phone Using the  
Infotainment System ..... 83

### Settings

Settings ..... 84

## Introduction

### Overview

As the model configuration or the supporting manufacturers are different, the audio entertainment system function, the display interface and the operation method may be different, such as video and entertainment, navigation, reverse camera, mobile phone interconnection, Bluetooth and telephone calls. For details about functional introduction and description of the audio entertainment system, please refer to the Vehicle Audio System Instructions placed in the glove box.

### Inspection before Repair

If you are unsure about certain audio function, before driving the vehicle to your dealer for repair, first read the directions given in the product instructions carefully and then check and operate according to the following table.

Symptom	Possible Causes and Solution
The host does not work and no information is shown on the screen.	Take out the host from the instrument panel, and then check the host fuse and connector to the vehicle.
The host works but no sound can be heard or the sound volume is very low.	Increase the sound volume and check the front/rear and left/right balance setup of the speaker.
The device body is a little hot.	The device heats normally as it works.
<p style="text-align: center;">Reception</p> The radio cannot search for the desired station.	<ul style="list-style-type: none"> <li>• Inspect whether the antenna is connected correctly</li> <li>• Inspect whether the antenna amplifier in the vehicle has been damaged.</li> <li>• Signal of the desired station is too weak and please tune manually.</li> </ul>
Certain audio files cannot be played via USB connection.	Confirm whether the device supports such audio files. Refer to the vehicle audio system instructions.
The sound volume fluctuates as MP3 songs are played.	As MP3 songs are of wide sources and no uniform standard applies. The reason can be that the volumes of MP3 songs are different as they are compressed. Turn the volume to adjust in case of this.
The singer/track/song name cannot be displayed.	The device does not support text display of the audio file.
The music pauses intermittently as it is played.	The reason can be that the format of the music file is different as it is compressed.



Symptom	Possible Causes and Solution
Songs stored in the memory device cannot be read.	Confirm that the storage partition form of the memory device is FAT16 or FAT32 as it is checked in the computer; if not, make new setup on the computer to change the format into a standard applicable to the device requirement.
MP3 songs cannot be read via an all-in-one USB adapter.	This device only supports song reading via an adapter with only one USB port.
Noise can be heard.	The noise can be produced by the device used to record the original audio file or it may be the noise existed at the time of recording. Use other players to play the file and then confirm whether the problem lies in this device.
If the fault still cannot be removed, see your dealer for inspection. Never disassemble the host to repair it yourself.	

## Home Page



When you turn the car ignition to the ACC position, the infotainment system will display the vehicle's logo while the system boots-up before displaying the home page. After 15 seconds, the infotainment system will use the last audio source used before the vehicle was turned off.

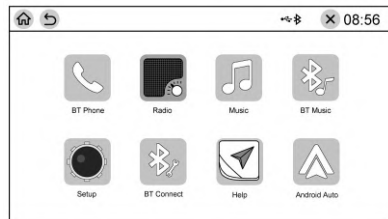

From the home page, you can access the Radio, BT Phone, Setup, Music, Apple CarPlay, Android Auto, and BT Music. The infotainment system displays the time in the top-right corner of the home page.

### Note

Do not keep the volume above 24 for more than 30 minutes, and always use air conditioning when driving in extreme heat. Other wise the vehicle will limit the volume to 10 and you will not be able to increase it further.

## Radio

### AM-FM Radio

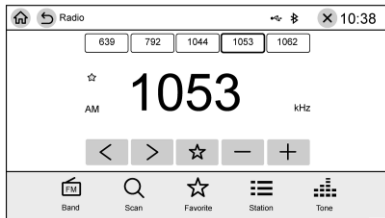

Enter the radio interface by clicking on the Radio logo in the main menu. Operations such as Band, Scan, Station, Favorite, and Tone can be carried on in the radio menu.

: Touch to return to the home page.

: Touch to scan for a lower frequency channel.

: Touch to scan for a higher frequency channel.

: Touch to decrease the channel frequency by one increment.

: Touch to increase the channel frequency by one increment.

: AM frequency band.

: FM frequency band.

: Touch to scan for channels from the current frequency to a higher frequency. When an effective channel is found, the radio will play audio for 10 seconds, and then it will scan for next effective channel.

: Touch to save the current frequency to the Favorites list.

## Audio Players

### USB



To open the Music Player, tap Music on the home page.

Tap or to play the previous or the next song. Press and hold or to play the current song in the fast rewind or fast forward mode.

Tap , , or to switch between repeat, random, and circular controls.

## Bluetooth Audio

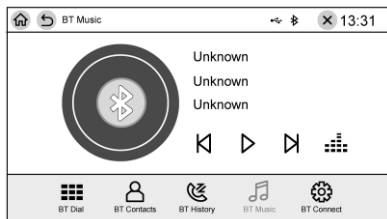

Music may be played from a paired Bluetooth device. Tap BT Music to open the Bluetooth music page.

▶ : Play the current song.

⏸ : Pause the current song.

⏮ : Play the previous song.

⏭ : Play the next song.

## Phone

### Bluetooth

#### Recent Calls

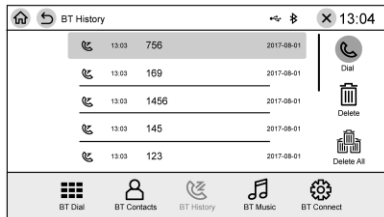

Tap BT History in the Bluetooth menu to enter the recent call list. You can view recent outgoing, incoming, and missed calls.

To view the recent call list, connect a phone via Bluetooth, accept the terms, and click download.

#### Note

You can delete one recent call record or all recent call records. To delete one call record, touch the Delete icon. To delete all call records, touch the Delete All icon.

## Contacts

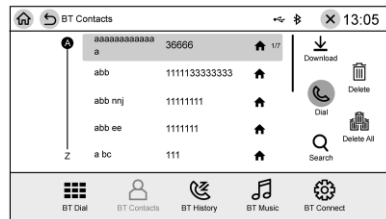



Tap BT Contacts in the Bluetooth menu to enter the contacts operation page. To view the contacts list, connect a phone via Bluetooth, accept the terms, and click download.

#### Note

To delete one contact, touch the Delete icon. To delete all contacts, touch the Delete All icon.

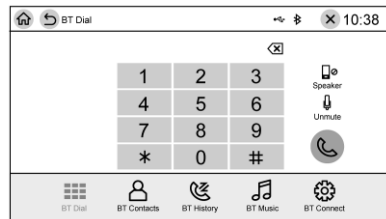
## Keypad



Tap BT Dial to open the keypad. To enter a phone number, tap the number keys and tap .

Tap the Speaker icon to transfer audio to your phone.

## Apple CarPlay and Android Auto

If equipped, Apple CarPlay and/or Android Auto capability may be available through a compatible smartphone.

### Apple CarPlay

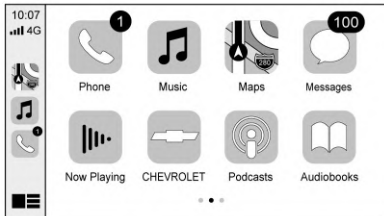

#### Note

- Supports Apple iPhone 5 and later iPhone models.
- It is recommended that the iPhone use iOS 9.0 later operating systems.

To use Apple CarPlay, plug in a compatible USB cable into the vehicle's USB data port, and into the iPhone. For best performance, use your device's factory-provided USB cable. Next, tap Apple CarPlay on the infotainment system home page. If the connection is successful, the Apple CarPlay menu displays.

To stop using Apple CarPlay disconnect the USB cable from the USB data port and the iPhone.

To use Apple CarPlay with an iPhone via a Bluetooth connection, first make sure the iPhone is not connected to the head unit with an Apple original USB cable. Next, open the Bluetooth menu in the infotainment system, and connect to the iPhone.

### Android Auto

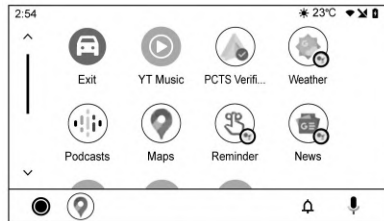

To use Android Auto, plug in a compatible phone USB cable to the vehicle's USB data port and to the Android smartphone. For best performance, use your device's factory-provided USB cable. Next, tap Android Auto on the infotainment system home page. If the connection is successful, the Android Auto menu displays.

To stop using Android Auto, disconnect the USB cable from the USB data port and the Android smartphone.

## Pairing a Phone Using the Infotainment System



Tap BT Connect on the home page to connect to a Bluetooth-capable phone.

Tap different options on the screen to operate the functions: Bluetooth On/Off, Auto Answer On/Off, and Auto Connect On/Off.

To connect a device, search for the name in the phone's Bluetooth device list, then select "pair" and accept the pairing. If the connection is successful, the phone name will appear in the list of registered devices.

To delete the device click the delete icon.

Make sure you turn on the Bluetooth on the phone before connecting to the infotainment system.

Do not pair Bluetooth devices when the vehicle is in motion.

## Settings

Tap Setup on the home page to open the Settings menu.

In the Settings menu, you can view and change infotainment settings including general settings, display settings, time settings, and system settings.

### General Setup

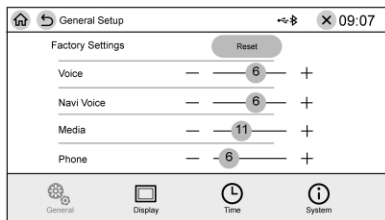

Tap General to open the General Setup settings menu.

To reset settings to the factory default settings, tap Reset for Factory Settings.

### Display Setup

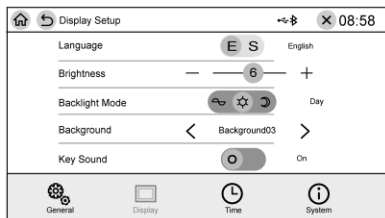

Tap Display to open the Display Setup menu. Functions such as Language, Brightness, Backlight Mode, and Background can be viewed and changed.

### Time Setup

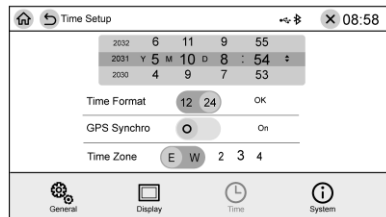

Tap Time to open the Time Setup menu.

In this menu you can set the time and date by sliding the numbers at the top.

Use the GPS Synchro to access to the manual time zone selection. Select East or West according to your location and choose the corresponding number to the city you are in. Refer to Table A1:

Table A1. Time Zones

City	Summer time	Regular time
Tijuana	W 7	W 8
Chihuahua	W 6	W 7
Mexico City	W 5	W 6
Quintana Roo	W 5	W 5

### Automatic Date and Time

If equipped, adjustment can be made by activating the GPS option.

### Note

The GPS signal may not be active in your area.

- Set time — Touch to manually set the time using the controls on the infotainment screen.

### System Info

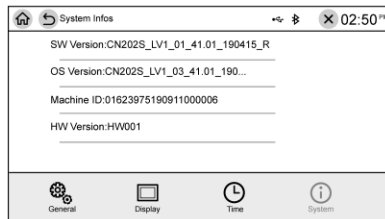

To open the System Information menu, tap System. In System Infos page, you can view software and hardware information.

### Sound Settings

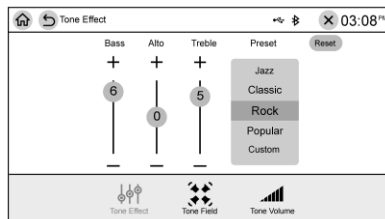

### Tone Effect

Tap Tone Effect to view and change tone settings.

Slide the moving bar or touch +/- to adjust the sound.

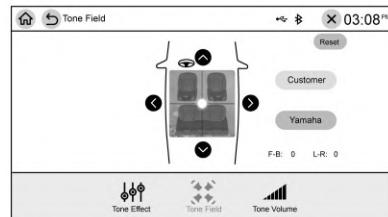

### Tone Field

Tap Tone Field to configure the audio. Tap Customer to manually configure tone field settings, or tap Yamaha to automatically configure tone field settings.

## Climate Controls

### Climate Control Systems

Climate Control Systems (Electronic Air Conditioning) .....	87
Air Conditioning System .....	101

### Air Vents

Air Vents .....	104
-----------------	-----

## Climate Control Systems

### Climate Control Systems (Electronic Air Conditioning)

Electronic A/C (If Equipped)

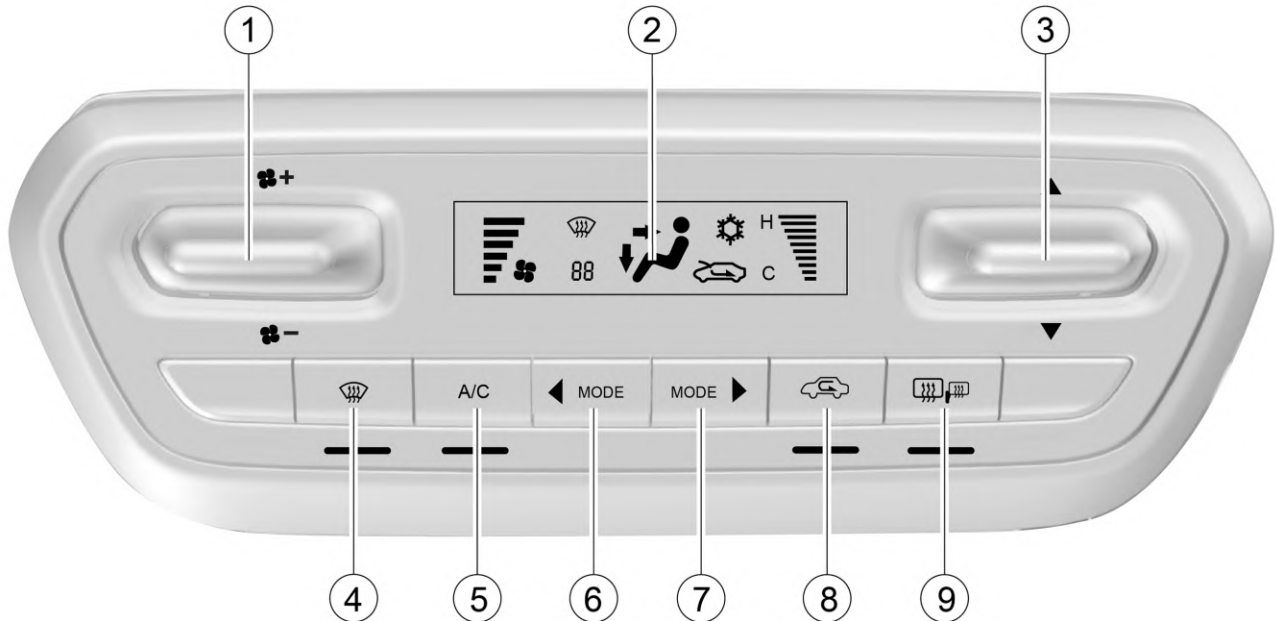



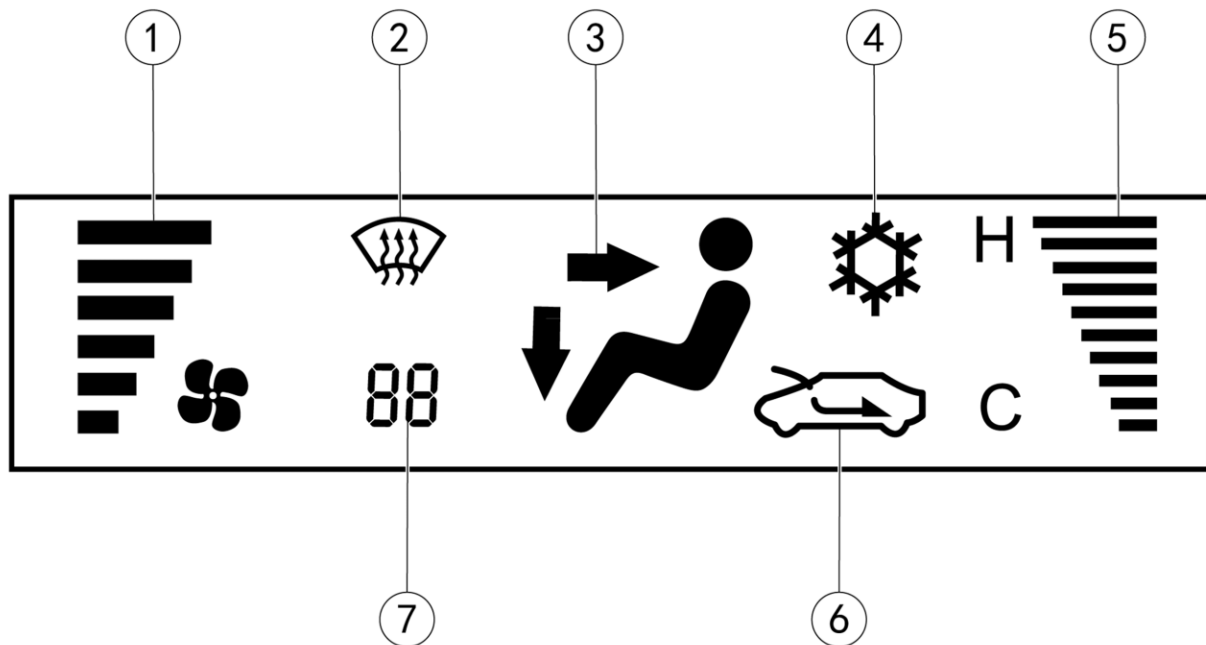

1. Fan Control Thumbwheel
2. Display
3. Temperature Control Thumbwheel
4. Front windshield defroster button
5. Air Conditioning (A/C) Button
6. Mode selection button (backward)
7. Mode selection button (forward)
8. Internal circulation button
9. Rear windshield defroster button

## Display



1. Air volume
2. Front defrosting mode
3. Blowing mode display (it can display face-blowing, face-blowing/foot-blowing, foot-blowing, foot-blowing/defrosting mode, etc.)
4. Cooling mode
5. Temperature
6. External circulation/ /Internal circulation  mode display
7. DTC

### Fan Control Thumbwheel

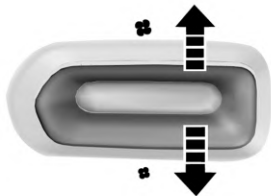

There are seven air volumes (including closing gear).

Pull the thumbwheel upwards or downwards once to increase or reduce the air volume by one range.

The air volume indication bar on the display screen displays the corresponding range.

If the air volume is at Range 1, pull the thumbwheel downwards once to turn off the air conditioning system.

If you pull upwards the fan switch after the air conditioning system has been turned off, the air conditioning system starts again and the start condition is shown on the display screen. At this time, the air volume is set at Range 1 and other states restore to the setups made before the system is turned off.

### Temperature Control Thumbwheel

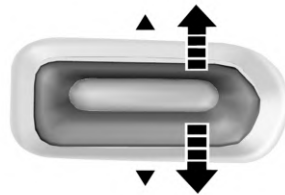

With the air volume switch is turned on, pull it upwards/downwards to increase or decrease the temperature. The temperature display bar on the display screen displays the temperature accordingly. “H” represents hot and “C” represents cool. Once the temperature reaches the hottest or coolest extent, if you pull the switch up again, the temperature stays unchanged.

If you pull the temperature switch after the air conditioning system has been turned off, the system starts again and the start condition is shown on the display screen. At this time, the

air volume is set at Range 1 and other states restore to the setups made before the system is turned off.

#### Front Windshield Defroster Button

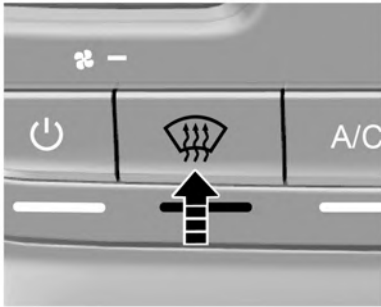

Press the front defrost button to turn on the front windshield defrost mode. The indicator under the button illuminates, the air circulation is automatically adjusted to the outer loop, the air conditioning cooling (A/C) is turned on, and the fan is automatically adjusted to “4th speed”. If the fan speed is already higher than speed 4 before the button is pressed, it will remain at the gear.

The display shows the defrost, outer loop, and A/C snowflake logo.

Press the button again to turn off the front defroster mode and the system restore to the state before defrosting.

#### Air Conditioning (A/C) Button

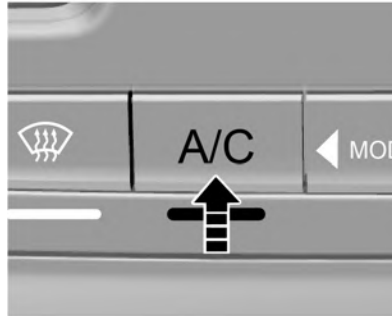

To turn on the air conditioning (A/C): When A/C is off, press the A/C button, the indicator under the button illuminates, and the display shows the snowflake logo. The air conditioner performs the cooling function.

To turn off: When A/C is on, press the A/C button and the snowflake logo on the display disappears. The air conditioner turns off the cooling function.

When the blower is off, press the A/C button. Then the fan will start 1st gear, A/C will be turned on, the air circulation mode, temperature and blowing mode will perform as the previous settings, and the display screen will be on.

The air conditioner can blow cold air only when the engine is running.

#### Mode Selection Button

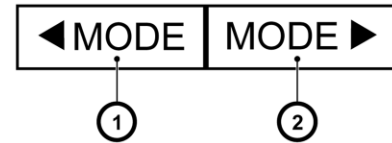

1. When the blower is on, press the mode selection front button one by one, and the blowing mode can be switched in the order of “face-blowing — face-blowing/foot-blowing — foot-blowing — foot-blowing/defrosting”. Press the rear



button to switch in reverse order. The display shows the corresponding mode icon. The corresponding air outlets in each air blowing mode are the same as the manual air conditioners.

- When the blower is off, press the mode selection button. Then the display is turned on, the blower is turned on in 1st gear, and other states such as temperature are operated as the previous settings.

### Internal Circulation Button



When the ignition is turned on, press this button to switch between the air inner and outer circulation modes. When using the inner loop mode, the indicator under the inner loop button illuminates.

The outer  or inner loop  status is displayed on the display accordingly.

When using the inner loop, the air circulates inside the vehicle, and long-term use may cause the glass to fog or make people sleepy. Note that switching to the outer loop mode to allow the fresh air in.

### Rear Windshield Defroster Button

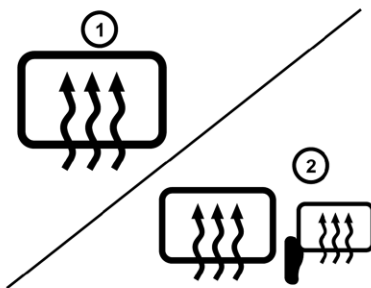

To turn on the defroster, first turn on the ignition and then press the rear windshield defroster button. The indicator under the button illuminates. Press again to turn off the defroster and the indicator under the button turns off.

After you press the button, the defroster will work for about 15 minutes and then turn off automatically.

If equipped with an outside rearview mirror defroster, this defroster also works while the rear windshield defroster works.

Use of the rear windshield defroster is prohibited under the following circumstances:

- The engine is not running.
- Snow or ice has deposited on the rear windshield

Using the rear windshield defroster under these circumstances can drain the vehicle battery.

**Warning**

Do not use a sharp cleaner or one that would cause glass wear when cleaning the rear windshield.

Lack of proper maintenance may cause damage to the defroster or scratches on the glass.

During vehicle cleaning or when operating near the rear windshield, take care not to shake or damage the defroster wire.

If the driver's view is affected, a crash can occur, causing personal injuries, damage to the vehicle, or property loss.

## Type-II — Automatic Constant Temperature A/C

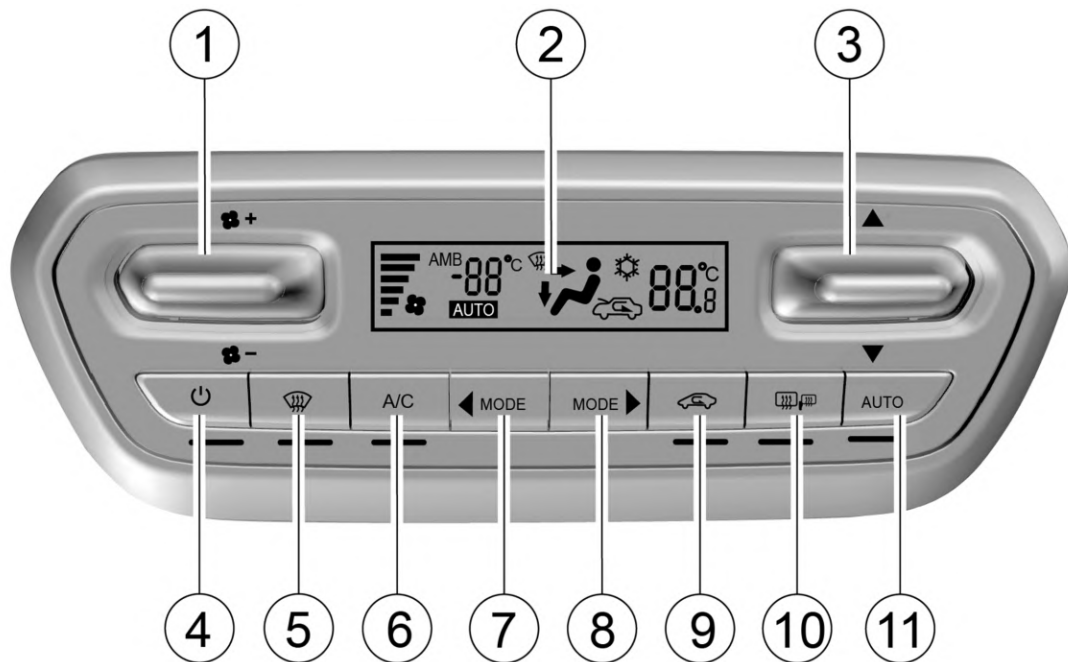



Control Panel

- 
1. Fan Control Thumbwheel
  2. Display
  3. Temperature Control Thumbwheel
  4. Power Switch
  5. Front Windshield Defroster Button
  6. Air Conditioning (A/C) Button
  7. Mode Selection Button (Backward)
  8. Mode Selection Button (Forward)
  9. Internal Circulation Button
  10. Rear Windshield Defroster Button
  11. Automatic Mode Button

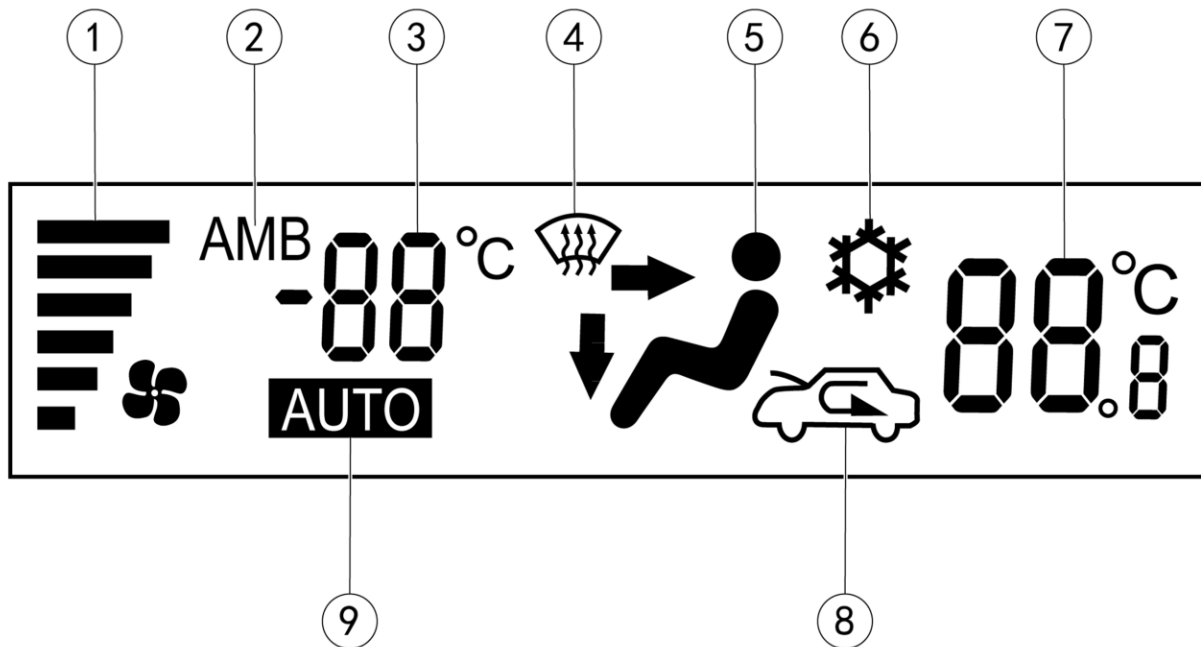



Control Panel

1. Air Volume
2. AMB Temperature Display
3. Outside Temperature
4. Front Defrosting Mode
5. Blowing Mode Display — Face-Blowing, Face-Blowing/Foot-Blowing, Foot-Blowing, Foot-Blowing/Defrosting Mode, Etc.)
6. Cooling Mode
7. Internal Temperature — Target Temperature
8. External Circulation/ /Internal Circulation  Mode Display
9. Automatic Mode

### Power Switch

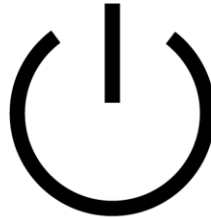

Press the power switch to turn the air conditioning system on or off. The indicator under the button turns on or off to indicate that the air conditioning system is on or off.

When the air conditioning system is turned on, the settings before shutdown will be restored.

### Fan Control Thumbwheel

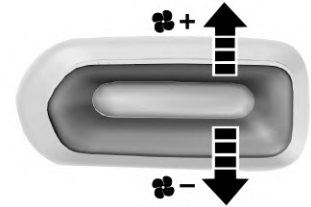

There are six air volumes.

Pull the thumbwheel upwards or downwards once to increase or reduce the air volume by one range.

The air volume indication bar on the display screen displays the corresponding range.

When the air volume is already at the maximum/minimum gear, the system remains at the gear even if the air volume is adjusted higher/lower.

When the air conditioner is powered off, the air volume switch can be adjusted to turn on the air conditioning system, and the air volume and temperature settings will be restored to the previous state.

### Temperature Control Thumbwheel

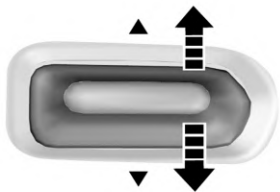

With the air volume switch is turned on, pull it upwards/downwards to increase or decrease the temperature. The temperature display bar on the display screen displays the temperature accordingly.

Once the temperature reaches the hottest (coolest) extent, if you pull the switch up again, the temperature stays unchanged.

When the air conditioner is powered off, the temperature switch can be adjusted to turn on the air conditioning system, and the air volume and temperature settings will be restored to the previous state.

### Front Windshield Defroster Button



Press the front defrost button to turn on the front windshield defrost mode. The indicator under the button illuminates, the air circulation is automatically adjusted to the outer loop, the air conditioning cooling (A/C) is turned on, and the fan is automatically adjusted to "4th gear". If the air volume is already higher than gear4 before the button is pressed, it will remain at the gear.

The display shows the defrost, outer loop, and A/C snowflake logo.

Press the button again to turn off the front defroster mode and the system restore to the state before defrosting.

### Air Conditioning (A/C) Button

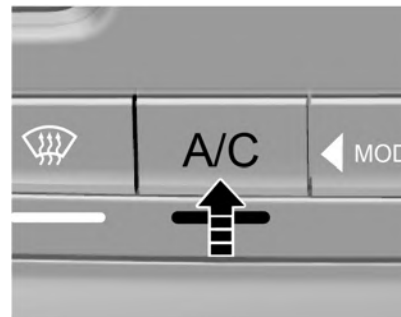

To turn on when A/C is off, press the A/C button, the indicator under the button illuminates, and the display shows the snowflake logo. The air conditioner performs the cooling function.

To turn off when A/C is on, press the A/C button and the snowflake logo on the display disappears. The air conditioner turns off the cooling function.

When the air conditioner power is off, press the A/C button to turn on the air conditioner system, and the A/C is turned on, other settings are restored to the previous state, and the display is turned on.

The air conditioner can blow cold air only when the engine is running.

### Mode Selection Button

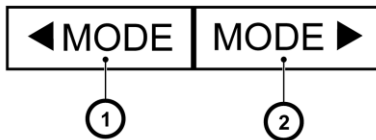

1. When the blower is on, press the mode selection front button one by one, and the blowing mode can be switched in the order of “face-blowing — face-blowing/foot-blowing — foot-blowing — foot-blowing/defrosting”. Press the rear button to switch in reverse order. The



display shows the corresponding mode icon. The corresponding air outlets in each air blowing mode are the same as the manual air conditioners.

2. When the air conditioner is powered off, press the mode selection button to turn on the air conditioning system, then the settings will be restored to the previous state, and the display will be turned on.

### Internal Circulation Button



When the ignition is turned on, press this button to switch between the air inner and outer circulation modes. When using the inner loop mode, the indicator under the inner loop button illuminates.

The outer  or inner loop  status is displayed on the display accordingly.

When using the inner loop, the air circulates inside the vehicle, and long-term use may cause the glass to fog or make people sleepy. Note that switching to the outer loop mode to allow the fresh air in.

### Rear Windshield Defroster Button

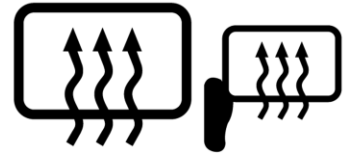

To turn on the defroster, first turn on the ignition and then press the rear windshield defroster button. The indicator under the button illuminates. Press again to turn off the defroster and the indicator under the button turns off.

Turn off the defroster in time after your view becomes clear. The defroster will also turn off automatically after working for about 15 minutes.

For models equipped with exterior mirror heating, if the rear defroster button is pressed to defrost the rear window, the exterior mirrors are also heated for defrost.

### Automatic Mode (AUTO) Button



In the AUTO mode, the A/C system automatically adjusts to keep the temperature inside the vehicle within a certain range.

Press the AUTO button, then the AUTO indicator on the display illuminates, and then move the temperature control switch

to select the desired interior temperature. At this time, the air volume, cooling/heating damper, A/C state, air distribution mode, and internal/external circulation mode all enter the automatic control state.

If manually adjusting the air volume and A/C state in automatic mode, the adjusted function is no longer automatically controlled by the system, and the AUTO indicator turns off. Unadjusted functions are still automatically controlled by the system.

When the A/C system is powered off, you can press the AUTO mode button to turn the A/C system on and enter the AUTO mode.

The air conditioning system will only perform cooling when the engine is running, and will only blow out the warm air when the temperature of engine water increases. Otherwise, the wind blown out is natural wind.



### Rapid Defrosting and Defogging

Operating in cold weather:

- Air conditioning switch (A/C): ON or OFF
- Air inlet mode: external circulation mode (the indicator turns off)
- Air distribution mode: 

- Temperature switch: red zone (warm air)
- Air volume switch: to the maximum
- Shift the air distribution mode to the foot/defrosting () mode to keep the front windshield clean and divert the warm air to the floor.

Operating in warm weather:

- Air conditioning switch (A/C): ON
- Air inlet mode: internal circulation mode (the indicator turns on) (). Switch it to the external circulation mode (the indicator turns off) after the fog lifts.
- Air distribution mode:  or 
- Temperature switch: to the area that ensures passenger comfort.
- Air volume switch: to the maximum

At the beginning of defrosting and defogging with the warm air, the fog can become thicker. Take care to ensure driving safety.

### Do Not Block The Sunlight Temperature Sensor

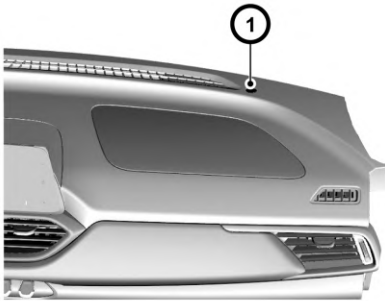

The automatic constant temperature A/C is equipped with sunlight temperature sensor located on the right side of the instrument panel near the front windshield.

The sunlight temperature sensor is used to sense the light intensity and input the desired signal for the operation of the automatic constant temperature A/C. Do not cover the sensor, otherwise, it will affect the A/C temperature control.

### Air Conditioning System

Refrigerating device of the air conditioning system is used to cool down the inside air and remove the moisture and dust contained in the air.

If the temperature set by the control thumbwheel is high, the vehicle will generate heat even if the air conditioning system is on.

After driving with the air conditioner on, sometimes you will see drops in the lower part of the engine compartment. It is normal phenomenon that these water drops are formed by the cooling system removing moisture from the air.

Since the compressor of the air conditioning system requires the engine to drive, you will find that the engine power and performance are reduced when the air conditioning is turned on.

### Air Conditioning (A/C) Button

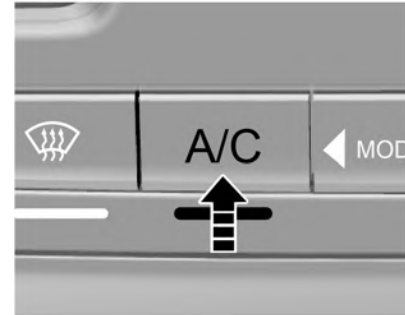

To turn on the air conditioning (A/C) system:

1. Start the engine.
2. Press the air conditioning (A/C) button. The indicator illuminates, indicating that the air conditioning system is working.
3. Adjust the fan speed.

The air conditioning system cannot work if the fan control thumbwheel is turned to OFF position (0 gear).

To turn off the air conditioning system:

1. Press the air conditioner (A/C) button again. The indicator turns off and the air conditioner stops working.

- If the air conditioning system was kept on when the engine was shut down the last time, the system will turn on automatically as the vehicle is restart.

Using the air conditioner when the slope is long or during the traffic jam can cause the engine to overheat. Observe the water temperature gauge. If it indicates that the engine is overheating, turn off the air conditioner. Otherwise, the vehicle will be damaged.

### Cool Air

To cool down fast in scorching hot days or after the vehicle is kept under the blazing sun for a long time:

#### Fast Cooling

- Open the door windows a little to expel the hot air inside.
- Turn on the air conditioning (A/C) system. The indicator illuminates at this time.
- Activate the internal circulation mode.
- Switch the air distribution mode to face mode (👤).
- Adjust the temperature to the maximum coolness.

- Adjust the fan speed to the maximum.

#### Normal Cooling

- Turn on the air conditioning (A/C) button. The indicator illuminates at this time.
- Activate the internal circulation mode.
- Switch the air distribution mode to face mode (👤) or dual mode (👤👤).
- Adjust the temperature to the cool air area.
- Adjust the fan speed to the desired value.

### Warm Air

#### Rapid Heating

Activate the rapid heating mode to increase the passenger area temperature quickly. It is prohibited to activate this mode for a long time, otherwise the inside air quality will decrease and fog can form on the windows. To clear up the fog on the windows, turn off the internal circulation mode so that fresh air enters inside.

To acquire the warmest air:

- Turn off the air conditioning (A/C) system. The indicator goes out at this time.
- Activate the internal circulation mode.

- Shift the air distribution mode to the foot mode (👤👤).
- Turn the temperature thumbwheel to the maximum position in the red area to get warm air.
- Turn the fan thumbwheel to the maximum speed.

#### Normal Heating

- Turn off the air conditioning (A/C) system. The indicator goes out at this time.
- Activate the external circulation.
- Shift the air distribution mode to the foot mode (👤👤) or dual mode (👤👤).
- Turn the temperature thumbwheel to the red area for warm air.
- Turn the fan thumbwheel to the desired speed.

### Ventilation

#### Dual Mode



This mode is applicable to cool and sunny days. Warm air is controlled to flow to the floor area and outside cool air is controlled to flow to upper portion of the compartment.

The method to use this setup is:

1. Disable the internal circulation key. The indicator goes out at this time.
2. Shift the air distribution mode to the dual mode ()
3. Turn the temperature thumbwheel to the desired temperature.
4. Turn the fan thumbwheel to the desired speed.

### Ventilation

To control the air to flow out from the central air outlet and the side air outlet:

1. Turn off the air conditioning (A/C) system. The indicator goes out at this time.
2. Activate the external circulation mode.
3. Shift the air distribution mode to the face mode () or dual mode ()
4. Turn the temperature thumbwheel to the blue area for cool air.
5. Turn the fan thumbwheel to the desired speed.



## Air Vents

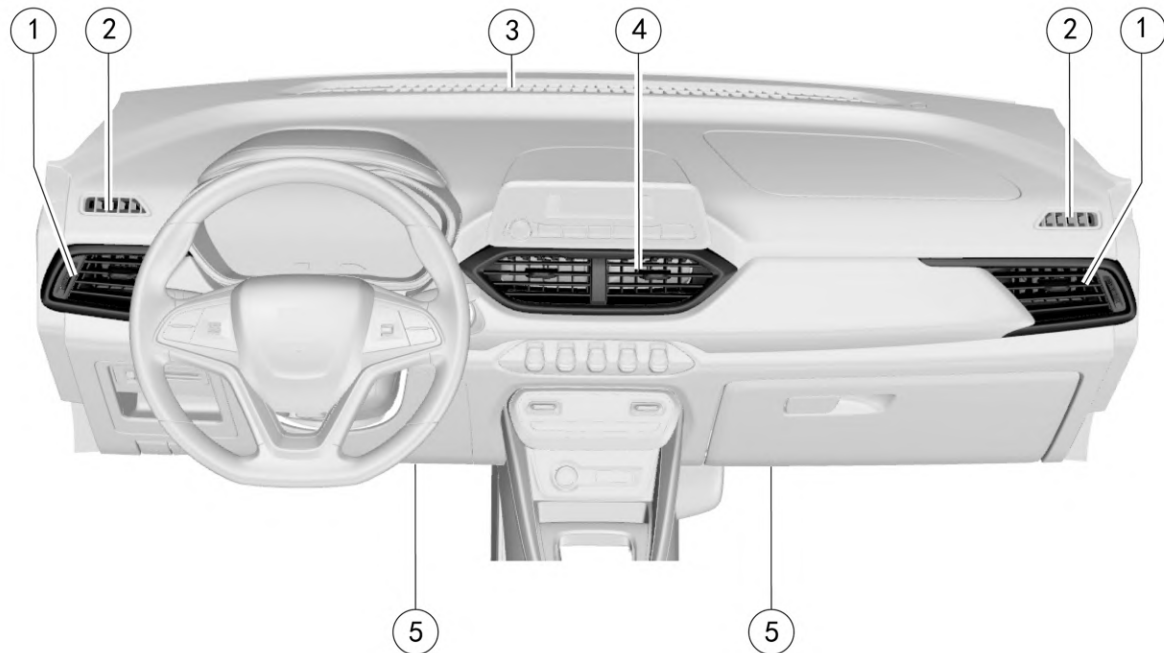

1. Side Air Outlet

2. Front Door Window Defogger Air Outlet

3. Front Windshield Defogger Air Outlet

4. Central Air Outlet
5. Floor Air Outlet

#### Side Air Outlet

You can adjust the air to both sides of the front riding area or the side door windows by operating the two adjustable side air outlets. Beside each air outlet, an air volume adjustment switch is located and you can operate the switch to adjust the air volume.

#### Front Door Window Defogger Air Outlet

The front door window defogger air outlet is used to divert the air to the side door window, mainly to the outside rearview mirror area.

#### Central Air Outlet

You can decide the flow direction of the air from the two adjustable central air outlets.

#### Front Windshield Defogger Air Outlet

The front windshield defogger air outlet is used to divert air to the front windshield.

#### Floor Air Outlet

The floor air outlet is used to divert the air to the front foot area.

#### Air Distribution Mode Knob



Adjust the air distribution knob to the desired mode so that the air flows in the desired direction. The air distribution knob can be set in one of the following five positions:

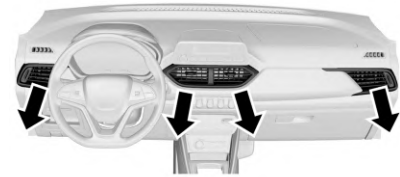

#### Face Mode (فم)

This mode setting allows air to be sent out from the central vents and side vents.

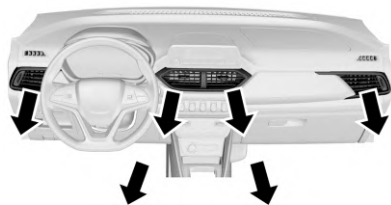

Dual Mode (نمط ٢)

In this mode, the air flows in two directions. Half of the air passes through the floor air outlets, and the rest of the air passes through the central and side air outlets.

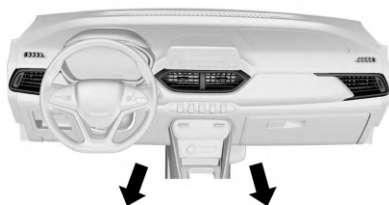

Foot Mode (نمط ٣)

Most of the air flows out from the floor air outlet, little amount of air flows out from the windshield and front door window defroster air outlet and the side air outlet.

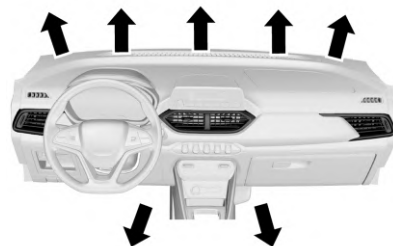

Foot/Defroster Mode (نمط ٤)

This mode allows air to be passed through the front windshield defroster vent, front door defroster vent, floor vent the side air outlet.

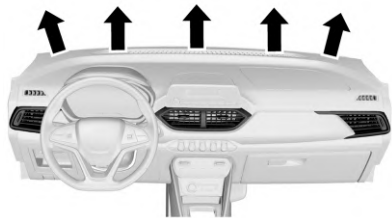

**Defrosting Mode** (  )

Air passes through the windshield and front door windshield defroster vents and side vents.

## Driving and Operating

### Driving Information

Control of a Vehicle .....	108
Steering .....	108
Off-Road Driving .....	109
Emergencies .....	110

### Starting and Operating

New Vehicle Break-In .....	111
Ignition Positions (Key Access) .....	112
Ignition Positions (Keyless Access) .....	113
Engine Starter Protection .....	114
Starting the Engine .....	114
Stop/Start System .....	115
Parking .....	116

### Automatic Transmission

Continuously Variable Transmission (CVT) .....	116
---	-----

### Manual Transmission

Manual Transmission .....	116
---------------------------	-----

### Brakes

Brakes .....	117
Antilock Brake System (ABS) .....	118
Parking Brake .....	119
Electric Parking Brake .....	120
Hill Start Assist (HSA) .....	120

### Ride Control Systems

Electronic Stability Control (ESC) .....	121
--	-----

### Cruise Control

Cruise Control .....	122
----------------------	-----

### Driver Assistance Systems

Assistance Systems for Parking or Backing .....	123
--	-----

### Fuel

Recommended Fuel .....	125
Filling the Tank .....	126

## Driving Information

### Control of a Vehicle

Do not allow the vehicle to slide when the engine is out of operation.

In such case, many systems (such as brake booster) cannot function. Driving in this way will form a danger to yourself and others.

### Pedal

To ensure that the pedal travel is unhampered, the floor mat in the pedal area should not be excessively thick, and no objects should be placed in the pedal area.

### Steering

#### Electronic Steering Column Lock

As the electronic steering column lock is used to lock the steering wheel, the vehicle having the ENGINE START STOP function is equipped with the electronic steering column lock at the same time. You can hear the operating sound when the lock device is started or released.

If locking the steering wheel is required, following conditions shall be met at the same time:

- The vehicle is motionless.

- The switch is at the LOCK position.

When conditions above are met, the steering wheel will be locked immediately if any one of following actions occur:

- Open or close the left front door.
- Remote locking
- 24 seconds have passed.

If unlocking the steering wheel is required, you can just enter the vehicle with the legal key and press the ENGINE START STOP switch.

In case that the steering column lock may be unable to be released when it is in the wheel-deviation forward direction, the instrument cluster will display “Failure in locking of electronic steering lock” and buzz for prompt. At this time, align the steering wheel, turn the switch at the ON position, and then switch to the LOCK position, to make efforts to unlock the steering wheel. If unlocking fails, see your dealer.

### Electric Power Steering (EPS) System

The EPS system provides the steering assist for the vehicle. The power steering fluid is not required for the system, which brings great convenience for the daily vehicle maintenance.

When the switch is connected, the EPS MIL illuminates momentarily. The EPS MIL does not go out or illuminates when the vehicle is running, indicating the EPS system is faulted. See your dealer.

When the EPS system is under extreme conditions of high load work for a long time (For example, the steering wheel is “turned to the end” for a long time, or the vehicle is moved into the garage at low speed repeatedly to a wide angle), the thermal protection function may be activated due to excessively high temperature of electrical elements.

The system will reduce the power assist after it enters the thermal protection state, and at the time you have to steer the wheel with great force. If the normal power assist need be recovered, you can steer the wheel at a smaller angle or promote the vehicle speed. You can restart the vehicle when necessary.

Strong electric and magnetic fields will cause interference to the EPS sensor, making the EPS system work abnormally. It may happen that the steering suddenly becomes lighter or heavier. In severe cases, it may turn automatically and a crash may occur. Therefore, do not drive into strong electrical or magnetic areas, such as radar radiation areas in

power plants and smelting plants. In general, these areas will be set up with corresponding warning signs.

The EPS system will adjust the power assist according to the vehicle speed. As a result, the steering wheel can be turned easily at low speed and be turned relatively steady at high speed.

### Off-Road Driving

When the vehicle is caught in snow, puddles or other unstable ground:

1. Vehicles equipped with ESC, press the ESC OFF switch first to turn off the ESC function.
2. Turn the steering wheel all the way to the left and then turn it all the way to the right. This will create a vacant area around the front wheels.
3. Engage the reverse gear and drive gear back and forth.
4. Reduce wheel idling as far as possible.
5. Release the accelerator pedal when shifting gear.
6. After engaging the gear, depress the accelerator pedal gently.

If this fails to get the vehicle out of trap, have the vehicle towed.

When the vehicle is caught in snow, puddle or sandy soil, you need to get the vehicle out of the trap as soon as possible.

First, check whether there are obstructions or people around the vehicle.

During this operation, the vehicle may suddenly move forward or backward, hitting the person or object next to it.

In order to avoid damage to the transmission and other parts, the following precautions must be observed when getting the vehicle out:

- Do not press the accelerator pedal during gear shifting or when the transmission is not in a proper gear position.
- High engine RPM is not allowed, and wheel idling should be avoided.
- If you cannot get the vehicle out after several tries, consider other methods, such as traction.

## Emergencies

The operation time of the starter motor should not exceed ten seconds. Otherwise, the starter motor will get damaged or discharge of battery will occur.

### One Tire is Punctured When the Vehicle is Running

If one tire is punctured when the vehicle is running, the driver should hold the steering wheel tightly to control the driving direction, slowly decelerate, turn on the hazard flasher, and gently depress the brake pedal to park your vehicle in a safe area.

Do not brake suddenly when one tire is punctured. Braking suddenly will cause the vehicle to tilt towards one side, and thus an accident may be caused.

### One Fault Exists When the Vehicle is Running

If a fault occurs when the vehicle is running, the driver should turn on the hazard flasher, slowly decelerate, and park the vehicle in a safe area at the curb.

Place a warning triangle at a position 50 m or more behind the vehicle in the daytime while placing it at a position 100 m or more behind the vehicle at night. Follow traffic laws and regulations.

See your dealer for inspection and maintenance.

Place the warning triangle in the luggage compartment, or have the dealer give it to you when the vehicle is being delivered.

### If the Engine Does Not Work

In case that the switch is at the “START” position, if the starter motor does not work, check whether the battery is dead, whether the battery port is connected correctly and whether relevant fuses are damaged.

If the starter motor works but the engine fails to be started, check fuel level, fuel filter, fuel pump, relevant wiring, etc.

The operation condition of the fuel pump can be preliminarily judged by hearing sounds made by the switch when it is being turned on.

### Measures Taken in Case of Engine Overheat

- When the vehicle is running, if the output power of the engine reduces suddenly or the warning lamp on the instrument cluster

indicating excessively high temperature illuminates, park your vehicle in a safe area and do following:

- Have the engine run at idle, and turn the transmission at the neutral.
- Pull the parking brake lever.
- Turn off the A/C.
- Open the hood to ventilate the engine.
- If the level of the coolant reservoir does not drop, stop the engine to cool it.
- If the coolant level is very low, uncover the reservoir, slowly fill water in the reservoir drop by drop till the level reaches the MAX (maximum) level mark of the coolant reservoir.
- After taking these steps, immediately see your dealer for inspection.

### Caution

Never put cold water in an overheated engine. It will cause damage to the engine. When the engine overheats, see your dealer.

Forcibly driving a problematic vehicle may lead to accidents.

### Warning

If steam or coolant escapes from the engine, do not open the engine cover as you may be scalded by the steam or coolant.

### Warning

Coolant from a hot cooling system can cause serious injury. If the coolant overflow recovery bottle cap is turned — even a little — the coolant can come out. Never turn the cap when the cooling system, including the coolant overflow recovery bottle cap, is hot. Wait for the cooling system and coolant overflow recovery bottle cap to cool if the cap ever has to be turned.

If you uncover the coolant reservoir, you can do it after the engine cools down completely. Apply one cloth to the cover, open it slightly at first (by one-third to one-half of a full turn), and then open it fully after pressure in the reservoir is completely released.

### Operation in Heavy Snow

- Decelerate when the vehicle turns a corner, upgrades or crosses a bridge.
- Do not park on a hard road shoulder; otherwise the snow shoveling work will be obstructed.
- Keep safe distance from other vehicles; braking unnecessarily will be limited.
- Clear accumulated snow around the vehicle frequently, to prevent the exhaust pipe from being blocked.

## Starting and Operating

### New Vehicle Break-In

Following measures can be taken within the initial mileage of 500 km, which can improve the performance, promote the vehicle economy and extend the service life:

- Avoid depressing the accelerator fully.
- Do not keep the engine idling for a long time.
- Avoid any emergency braking except in an emergency. With this, the brake can run in well.



- Do not quickly start, accelerate suddenly and continuously keep the vehicle running at high speed if possible, to avoid any damage to the engine and save the fuel.
- Avoid accelerating by depressing the accelerator fully at a low gear and driving by depressing the accelerator greatly.
- Do not tow any other vehicle.
- Do not use features such as the radio and headlamps for a long time when the engine is off. When getting out of the vehicle, shut down the electric equipment for the vehicle, to avoid draining the battery. If the battery drains, the vehicle may fail to start.

## Ignition Positions (Key Access)

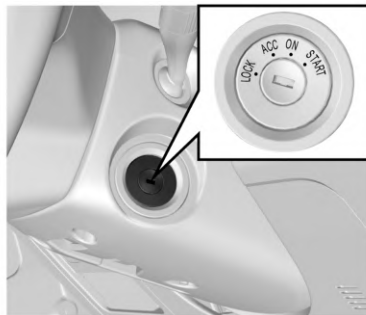

When the ignition is turned at the right side of the steering column, the operating positions are as follows:

### LOCK

Lock the steering wheel. Remove the key and turn the steering wheel until it is locked.

If you cannot turn the key when unlocking the steering wheel, gently turn the steering wheel right/left and turn the key.

### ACC

When the ignition key is at the ACC position, some electrical accessories such as the radio and cigar lighter can be used.

When the ignition is in the ACC position, the engine is turned off and the steering wheel is unlocked.

If you are to turn the ignition key from the ACC position to the LOCK position, you can gently press in the key and turn the key to the LOCK position.

Do not leave the key in the ACC position for long period of time. Otherwise the battery will be discharged.

### ON

Connect the ignition system and electrical accessories.

Do not keep the key in the ON position for a long time when the engine is out of operation; otherwise the battery will have insufficient voltage.

### START

Start the engine. After starting the engine, release the key; the key will automatically return to the ON position.

Confirm that the engine does not operate before turning the ignition key to the START position.

### Caution

Never remove the key or turn the key in the ignition while driving. Otherwise, the driver would lose control of the vehicle and the brake assistance will not function properly, which can cause vehicle damage and injury or death.

## Ignition Positions (Keyless Access)

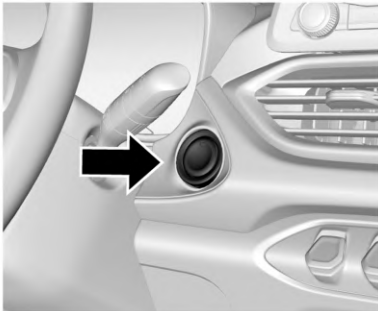

If equipped, the ENGINE START STOP switch is at the lower right side of the instrument panel.

Working indicator on ENGINE START STOP switch:

- Orange: Indicates that the ignition is at the ACC or ON position.
- Green: Indicates that the start conditions are met.

When the working indicator turns green, if the transmission is at the neutral or P (AT model) position, press the start switch and then the engine can be started.

When the power is switched from the low voltage to the high voltage, the system must be able to detect the legal key. Place the key at one position near the ENGINE START STOP switch inside the vehicle, such as driver's pocket or instrument panel storage box.

In the sequence from the low voltage to the high voltage of power, the operating positions are as follows: LOCK, ACC, ON and START.

### LOCK

The vehicle is parked at this position. The working indicator on the ENGINE START STOP switch does not illuminate and the vehicle power is off.

### ACC

Press the ENGINE START STOP switch at the LOCK position; the position can be switched to the ACC position. The orange working indicator on the ENGINE START STOP switch starts to illuminate. The power of some electrical accessories such as the radio and cigar lighter is enabled.

If no operation is conducted, the system will automatically return to the LOCK position one hour later, to reduce the consumed power.

### ON

The vehicle can be started and driven in this position

Press the ENGINE START STOP switch at the ACC position once; the position can be switched to the ON position. The instrument cluster indicator illuminates, and the orange indicator on the ENGINE START STOP switch illuminates.

If you press the ENGINE START STOP switch once (without other operations) at the ON position, the switch will be turned to LOCK position.

### START

At the ON position, shift the transmission to neutral and press the clutch pedal (for MT model) or brake pedal (for AT model). Then

the green indicator on the ENGINE START STOP switch illuminates. Press the ENGINE START STOP switch once, and the engine will start. After the engine starts, the ignition stays at the ON position.

### OFF

Press the start switch once the vehicle is completed stopped.

Do not release the clutch pedal or brake pedal (AT model) while the engine is starting, otherwise the engine may not start successfully. If the transmission is not at the neutral or P (AT model) position, the engine cannot start.

Never keep the engine idling at high speed for over 5 minutes. Excess temperature will damage the exhaust system.

### Engine Starter Protection

The vehicle with the engine immobilizer system has extra anti-theft capacity to prevent any unauthorized person from starting the vehicle. The matching key of the engine immobilizer system has been encoded electronically. The electronic transceiver is concealed in the ignition key. Only a valid key can be used to start the engine. However,

an invalid key can also be used to open doors. The engine immobilizer system isolates the power supply from the ignition system, the fuel pump and the fuel injector. When any unauthorized person turns the invalid key to the START position, the engine immobilizer system fails to identify the electronic code. Therefore, the engine cannot start and the immobilizer system indicator will be flashing.

If equipped, a mechanical lock on the steering wheel will better protect against theft.

### Starting the Engine

Before starting the engine:

- Ensure that no barriers exist around the vehicle.
- Ensure that all windows and doors are clean and transparent.
- Check whether the tire conditions and the inflation pressure are proper and whether obstacle/object exist.
- Adjust the seat headrest to a proper position.
- Adjust the rearview mirrors inside/outside the vehicle.

- Fasten the safety belt and ask all passengers to fasten safety belts.
- When turning the key at the ON position, check the operating conditions of the warning lamp and the indicator on the instrument panel.
- Regularly (for example, when refueling) check the maintenance items recorded in Maintenance and Warranty Manuals.

### Engine Starting:

1. Ensure that the driver and passengers have properly secured their seat belts.
2. Apply the parking brake.
3. Ensure that seats and rearview mirrors are at proper positions. Adjust them if necessary.
4. Turn the ignition at the ON position.
5. For MT model make sure the clutch pedal is pressed fully or the gearshift lever is at the neutral position; press the brake pedal for the AT model.
6. Do not depress the accelerator pedal, turn the ignition-switch key to the ON position, and release the clutch (or brake) pedal after the engine starts. For one model having

the ENGINE START STOP function, click the ENGINE START STOP switch once to start the engine. If the engine starts temporarily and fails to operate, you can wait for ten seconds and then try again.

- Keep the engine idling for more than 30 seconds to heat the engine.
- Release the park brake.
- Do not drive the vehicle at high speed before the engine temperature reaches the normal operating temperature.

Do not keep the starter running continuously for over ten seconds. At high altitudes or low temperatures, vehicles may have difficulty starting up. If the engine fails to start, wait ten seconds and then restart to avoid any damage to the starter.

## Stop/Start System

Following conditions should be met for engine start:

### Start Condition

- The key is inside the vehicle.

- Press the clutch pedal for manual transmission or brake pedal for automatic transmission.

If conditions above are met, the green indicator on the ENGINE START STOP switch will illuminate. In this case, if the gear is at the neutral position, press the start switch and the engine will immediately start.

### Other Control Instructions

#### 1. Emergency start

- The clutch switch failure will make the start conditions unable to be met, and the engine cannot start normally.

Turn the ignition to the ACC position, confirm that the transmission is in N (Neutral) and then press and hold the ENGINE START STOP button for 15 seconds. This will start the engine.

- A low transmitter battery may cause the system to fail to search for the key and thus the engine fails to start. In this case, press the clutch pedal (brake pedal for automatic transmission), and at the same time attach the side of the transmitter

with the emblem close to the ENGINE START STOP button. When the green indicator on the ENGINE START STOP button illuminates, press the button to start the engine. Try again if this does not work. Replace the battery in the transmitter.

#### 2. Emergency flameout

If emergency shut off of the engine is required when the vehicle is running, press and hold the ENGINE START STOP button for two seconds or continuously press for three times within three seconds.

### Danger

Never operate the ENGINE START STOP switch when the vehicle is running. Accidental vehicle flameout may suspend braking and assistance of the steering system. The driver could lose control of the vehicle causing severe damage and the possibility of a crash causing death.

## Parking

- When the parking brake is used for parking, the button must be released after parking. When parking on a ramp, tension the parking brake as tightly as possible and depress the brake pedal at the same time.
- Shut down the engine and turn off the ignition. Turn the steering wheel till the steering wheel is locked by the steering wheel lock.
- When parking the vehicle on one uphill ramp, turn the front wheels away from the road shoulder. When parking the vehicle on one downhill ramp, turn the front wheels towards the road shoulder.

Parking on a hill for MT model:

1. Turn the gearshift lever to the neutral gear when parking the vehicle on the horizontal ground.
2. Turn the gearshift lever to the reverse (R) gear when parking the vehicle towards the downhill direction.
3. Turn the gearshift lever to the 1st gear when parking the vehicle towards the uphill direction.

4. Engage Gear P (AT model) for all pavements when parking.

### Caution

Flammable objects could touch hot exhaust parts under your vehicle and ignite. Do not park over papers, leaves, dry grass or other things that can burn.

## Automatic Transmission Continuously Variable Transmission (CVT)

Your vehicle may be equipped with a Continuously Variable Transmission (CVT).

A CVT can continuously change the transmission ratio, which is equivalent to having innumerable gears, making gear shifting smoother.

Instruction for use:

1. Before starting the engine, depress the brake pedal first to confirm that the transmission shift lever is in P gear.
2. Depress the brake pedal and then engage a gear after starting the engine.

3. After engaging a gear, continue to depress the brake pedal, release the hand brake, and release the brake pedal when starting the vehicle.
4. After the brake pedal is released on smooth pavement, the vehicle will start running automatically and slowly with the accelerator pedal not depressed.
5. It is not recommended to coast in neutral gear during driving. Otherwise, the transmission will be damaged or an accident will occur.

## Manual Transmission

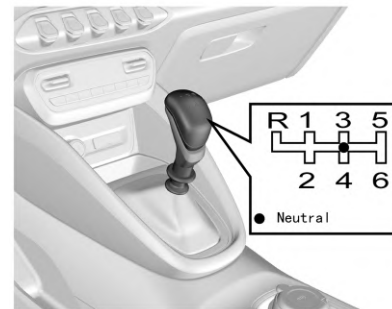

Shift gears according to the pattern on the shift lever after the clutch is released. If you have to shift to R (Reverse), first stop the vehicle, completely press the clutch pedal, and then shift from Neutral to R (Reverse).

- 1: First drive gear
- 2: Second drive gear
- 3: Third drive gear
- 4: Fourth drive gear
- 5: Fifth drive gear
- 6: Sixth drive gear (if any)
- R: Reverse gear

Press the clutch pedal completely when shifting gear.

Do not always put your foot on the clutch pedal during driving.

### Operation of Reverse Gear (R)

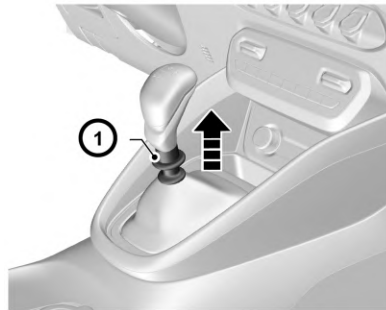

When shifting the transmission with six drive gears to R (Reverse), pull up the reverse gear lock ring (1) and then turn the shift lever from the Neutral to R (Reverse).

Do not pull the reverse gear lock ring when shifting to the drive gear to avoid from shifting to the R (Reverse) accidentally.

When shifting between the drive gear and R (Reverse), ensure that the vehicle comes to a complete stop. After completely pressing the clutch, wait for a moment and engage a gear. Otherwise, the transmission may get damaged or the transmission life may be shortened.

When backing up, start slowly and confirm that the shift lever is in R (Reverse). Engaging the wrong gear could cause a crash.

Always putting your foot on the clutch pedal when driving will damage the engine and the clutch system and increase the amount of fuel consumed.

### Brakes

- The brake system is designed for the braking performance under the driving conditions in wide range. In the braking process, the vehicle speed is reduced through the braking friction and the friction between tires and ground. It is normal that small braking friction sounds and friction sounds between tires and ground are given with no need for special treatment. It is also normal that occasional squeals are given in braking. Squeals may be produced for such causes that other matters may adhere to the friction faces during operation of the vehicle, the vehicle is out of operation for a long time, or friction faces get rusted after raining. As long as squeals are produced at a lower frequency, there is no need for special treatment.

- To avoid the pedal travel from being influenced, do not lay a thick carpet in the brake pedal area.
- If the brake pedal fails to return or the brake pedal travel becomes longer, this may indicate a faulty brake system.

When you drive your vehicle in a high-altitude area, continuously braking may cause the brake pedal force to increase.

To ensure proper brake system performance when the vehicle is new or after installing new brake pads, avoid emergency braking or extended braking within the first 200 km.

### Warning

After driving through deep water, washing the vehicle, or using the brakes excessively when going down a steep hill, the brakes can temporarily lose their stopping power. This may be due to wet brake components or overheating.

If your brakes temporarily lose their stopping power because of overheating: Shift to a lower gear when going down hills. Do not continuously apply the brakes.

(Continued)

### Warning (Continued)

If your brakes temporarily lose their power because of wet brake components, the following procedure will help restore their normal performance:

1. Check behind you for other vehicles.
2. Keep a safe forward speed with plenty of space to your rear and sides.
3. Gently apply the brakes until normal performance is restored.

### Warning

When EVP warning light illuminates (if equipped), it indicates EVP fault has occurred, the brake pedal will be hard to press down, see your dealer to inspect and repair the EVP system as soon as possible.

## Antilock Brake System (ABS)

As an advanced electric braking system, the Antilock Brake system (ABS) is helpful in the vehicle from slipping and losing control, and this system can also provide maximum braking capability on slippery pavement.

When the ignition is turned on, the ABS warning lamp illuminates momentarily. If the ABS warning lamp does not go out or illuminates when the vehicle is running, it indicates that the ABS is faulty. See your dealer.

See *Antilock Brake System (ABS) Warning Light* ⇨ 62

The ABS will monitor the speed of each wheel during braking. If one wheel tends to be locked, the system will control brakes of two front wheels and two rear wheels respectively. When the ABS works, the brake pedal often vibrates slightly with noise.

The ABS will neither change the time required for brake engagement, nor shorten the braking distance. Sufficient braking distance must be kept even with ABS.

### Warning

The braking distance on slippery road surfaces is longer than that on a normal dry paved road even with an ABS-equipped vehicle. When ABS is activated in the following road surface conditions, the braking distance may be slightly longer

(Continued)

### Warning (Continued)

compared to that of vehicles not equipped with an ABS. Therefore, always be aware of the road and tire condition (tire type and wear condition), observe safe driving habits, and drive the vehicle while keeping a safe following distance.

Follow the above guidelines especially in these conditions:

- When driving on a gravel road and deep snow-covered road.
- When tire chains are used.
- When driving over road joints or bumps such as light reflectors on the road.
- When driving on a bumpy road, stone-paved road or track.
- When driving over an iron plate or manhole lid.

ABS does not work for wheel skidding during a standing start, acceleration and cornering that does not involve braking. On a very slippery icy road, tires may lose their grip and the steering wheel operation may not be able to control the vehicle's direction,

(Continued)

### Warning (Continued)

resulting in very unstable driving. Always drive the vehicle observing a safe speed well matched with both road surface and tire conditions, and avoid sudden braking if possible.

If powerful engine braking is applied on a very slippery icy road, the drive wheels may be locked (the ABS then does not work), resulting in loss of vehicle control.

ABS operation consumes the brake system air. When the air pressure drops and the brake air pressure warning light and the chime are activated, immediately stop the vehicle at a safe place and wait for the required air pressure to be recovered before resuming driving.

When ABS is activated, slight vibration and pull to one side may be felt on the steering wheel, especially when the road surface condition is different between the right and left wheels. In addition, an operating sound is produced from the ABS actuators. This does not indicate any abnormal condition. Stay calm and operate the steering wheel properly.

### Parking Brake

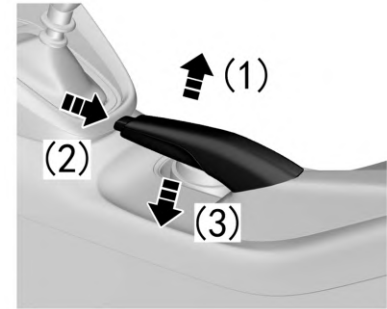

The parking brake impacts rear wheels.

The parking brake lever is between two front-row seats. If you are to use the parking brake, you should stop the vehicle, press the brake pedal and pull the parking brake lever.

To release the parking brake:

1. Press the brake pedal.
2. Pull back the parking brake lever slightly.
3. Press the button on the parking brake lever joint.
4. Release the parking brake lever when holding the button.



### Caution

If the parking brake does not engage correctly, the vehicle, in some cases (such as when parking on a slope), may move by itself due to loss of control, thus causing danger. Have it adjusted by an authorized dealer, if necessary.

Do not drive the vehicle with the parking brake not released; otherwise the rear wheel brake may get overheated or be subject to premature wear. As a result, you must replace the rear wheel brake; other components of the vehicle may get damaged.

## Electric Parking Brake

### Electric Brake Force Distribution (EBD) System

The EBD system uses the high-speed computer to respectively induce and calculate different ground to which four wheels are attached, and thus calculate different friction values at the moment the vehicle brakes. Therefore, four wheels can be able to brake in different ways

and force based on different conditions, and can be adjusted fast during movement, so as to ensure that the vehicle is stable and safe.

### Hill Start Assist (HSA)

The ESC system has the HSA function. The function can help the vehicle to start easily on a slope without using the parking brake.

Whether the driver is driving or reversing onto a hill, the start assistant is provided through the function. Therefore, engage gear before starting.

When the hill-start hold control functions, after the brake pedal is released, the vehicle still keeps the braking force for one to two seconds. In this case, the vehicle will not slide backwards.

For manual transmission vehicle, the driver can focus on engagement of accelerator and clutch in two seconds, to deal with the tense hill-start with ease.

Within those two seconds, if the driving force applied by the driver is greater than the resistance which the vehicle is subject to while on a grade, the system will gradually reduce the braking force and the vehicle will start running smoothly. If the vehicle fails to start running in two seconds, or the driving

force applied by the driver is insufficient, the pressure of the brake system is released automatically and the vehicle may start sliding down the hill. Press the brake pedal to make the vehicle come to a complete stop, and the system will still help with the next start when conditions are met.

Conditions for the HSA system to function:

1. No fault exists on the system, and the engine has been operating;
2. The vehicle is motionless and the brake pedal is pressed;
3. The system detects that the grade is met. (In theory, when the grade is less than 4%, the vehicle will dip during braking, and the dipping angle will offset the grade. As a result, the system may fail to start on a hill when the grade is less than 4%.)
4. When the vehicle is reversed onto a slope, it is necessary to set to the reverse gear first.

The HSA function may fail to prevent the vehicle from sliding on a very slippery or steep hillside.

The HSA function cannot supersede the parking brake function. Always set the parking brake when getting out of the vehicle. If there

is no sufficient driving force provided after the brake pedal is released, the vehicle will slide backward. Immediately pull back on the parking brake and press the park pedal.

If the engine shuts off during the process, immediately pull back on the parking brake and press the brake pedal.

## Ride Control Systems

### Electronic Stability Control (ESC)

The Electronic Stability Control (ESC) system is a safety system, representing the further development of the functions of anti-lock brake system (ABS) and traction control system (TCS). In addition, the yaw rate sensor, lateral acceleration sensor and steering wheel turn angle sensor are added. The driving force and braking force of front and rear, left and right wheels are controlled through the ECU, which ensures the lateral stability of the vehicle. When the driver operates the vehicle beyond the limit values, in case of turning at high speed, the ESC system automatically intervenes to ensure that the vehicle can be controlled safely.

Indicators relevant to the ESC system consist of ABS MIL, electronic brake-force distribution (EBD) MIL, ESC MIL and ESC OFF indicator.

1. Indicators illuminate for self-inspect when the ignition is connected. The four indicators are normally on for three seconds, indicating that the ESC system is conducting self-inspect and indicators work normally. The four indicators go out three seconds later under the normal condition. When faults (such as neglected installation, loosened connector, abnormal CAN communication) exist on the ESC system, only the ESC OFF lamp will go out three seconds later, and other three lamps are normally on.
2. In the process of driving the vehicle, if the ESC function is activated, the ESC lamp will flash, telling the user that the ESC system is working. If the ESC system functions abnormally but the ABS+EBD system functions normally, the ESC lamp is normally on, indicating that the ESC system has fault. If the ESC system and the ABS function abnormally and the EBD system functions normally, the ESC lamp and the ABS lamp are normally on. If the

ESC system, the ABS and the EBD system function abnormally, the ESC lamp, the ABS lamp and the EBD lamp are normally on.

3. The ESC OFF lamp is used to indicate that the ESC function is disabled (the lamp will be normally on as long as the ESC function is disabled; the lamp will go out if the function is enabled). If you press the ESC OFF switch, some ESC functions will be disabled, and the ESC OFF lamp illuminates. When the switch is pressed, the ESC system is working, and the ESC function will not be disabled immediately and will be disabled after the work is over. If you press the ESC switch again, all functions will be enabled again. If the ESC switch is pressed for more than 10 seconds, the ESC system will consider it one incorrect operation, and the ESC function will not be disabled.
4. The ESC system will be activated automatically after every ignition cycle.

## ESC OFF Switch



Press the ESC OFF switch, and the ESC OFF lamp on the instrument cluster illuminates and some ESC functions are disabled. Press the ESC switch again, the ESC function is enabled again and the ESC OFF lamp on the instrument cluster goes out.

Normally, it is not recommended to disable the ESC system. The system should be disabled temporarily only when the vehicle is in deep mud, sand, ice, or snow.

## Cruise Control

### Cruise Control System





The cruise control buttons are on the steering wheel. When the cruise control system is started, the vehicle can run at the set speed. Press the brake pedal, and the function will be immediately disabled. Except the brake pedal is used to disable the function, operating switches such as parking brake switch and clutch switch can also be used to disable the function of the cruise control system.

For MT model, the system can be used at 3 (Third), 4 (Fourth), 5 (Fifth) and 6 (Sixth) gears with the speed ranges from 40–120 km/h when the engine speed is lower than 4800 rpm.



For CVT model, the system can be used with speed ranges from 40-160 km/h.

### 1. Setting Cruise Control

Press the  button, and the cruise indicator on the instrument cluster starts to flash, indicating that cruise control is active. Then pull the middle button toward SET- direction, the cruise will start, and the corresponding logo will be displayed in the dashboard information window. (For example, when the driver intends to stabilize the speed at 100 km/h, the driver must firstly speed up to 100 km/h. When the speed reaches 100 km/h, he/she shall press the , toggle button and then pull the toggle button towards the SET- direction. At this time, release the accelerator pedal, and the vehicle will continuously run at the speed of 100 km/h. After setting the cruising speed, you can also use the accelerator pedal to accelerate in the normal method; after the accelerator pedal is released, the system will recover the speed to the original cruising speed.

After enabling the cruise function, never move the shift lever into neutral without stepping on the clutch pedal. Otherwise, the engine may over speed and be damaged.

## 2. Deactivating Cruise Control

If you are to immediately decelerate in case of any emergency in front during cruise control, press the brake pedal or clutch pedal, or press the cruise deactivation button  or pull the toggle button towards  direction. The vehicle exits the current cruise state and enters the cruise activation state, and the cruise indicator of flashes. If you press the  button in the cruise state, the whole cruise system will be deactivated and the instrument indicator will go out.

## 3. Cruise Recovery

When the vehicle exits from the cruise state and enters the cruise activation state, if you are to carry out the cruise control at the previous cruising speed, you just need pull the toggle button once towards the RES+ direction. Then cruise control is carried out at the previously-saved speed recovered. For example, the cruising speed is 60 km/h

before braking and becomes 50 km/h after braking, and at the time the cruise indicator of instrument flickers. Pull the toggle button once towards the RES+ direction; the cruise indicator will be normally on, and the vehicle will automatically speed up to 60 km/h and enter the cruise control state.

## 4. Increase Cruise Control Speed

Pull the toggle button towards the RES+ direction and the set cruising speed will rise without the need to press the accelerator pedal. The speed will rise by 2 km/h (MT), 1 km/h (CVT) every time you pull up the switch once. If the toggle button is kept pressed, the vehicle speed will continuously rise. Once the switch is released, the running speed will be saved into the memory and the vehicle will cruise at the speed.

## 5. Decrease Cruise Control Speed

Pull the toggle button towards the SET- direction to reduce the cruising speed. The speed will reduce by 2 km/h (MT), 1 km/h (CVT) every time you pull down the switch once. If the toggle button is kept pressed, the vehicle speed will continuously reduce. Once the control lever is released, the then running speed will be saved into the

memory and the vehicle will cruise at the speed. If the toggle button is released when the vehicle speed reduces to about 40 km/h (less than 40 km/h), the saved value will be deleted. If you are to continuously drive at the cruise control speed, you need reset the cruising speed.

### Warning

Cruise control can be dangerous where you cannot drive safely at a steady speed. Do not use cruise control on winding roads or in heavy traffic.

Cruise control can be dangerous on slippery roads. On such roads, fast changes in tire traction can cause excessive wheel slip, and you could lose control. Do not use cruise control on slippery roads.

## Driver Assistance Systems

### Assistance Systems for Parking or Backing

The intelligent reverse sensor judges the distance between rear end of the vehicle and the obstacle via the ultrasonic transducer installed on the rear bumper.

Turn on the ignition, and shift to REVERSE gear. If the buzzer buzzes once, it indicates normal system.

If the buzzer sounds for a period of time (about five seconds), it indicates that the sensor or system is faulty.

The intelligent reverse sensor starts to work immediately every time you turn on the ignition, release the park brake and shift to reverse gear.

When the distance between the vehicle and the obstacle behind it is within about 1.5–1.0 m, the reverse buzzer sends out alarm sound at slow intervals.

When the distance between the vehicle and the obstacle behind it is within about 1.0–0.6 m, the reverse buzzer sends out alarm sound at intervals.

When the distance between the vehicle and the obstacle behind it is within about 0.6–0.3 m, the reverse buzzer sends out alarm sound at faster intervals.

When the distance between the vehicle and the obstacle behind it is within about 0.3 m, the reverse buzzer sends out alarm sound constantly.

- To ensure reversing safety and to leave enough time for the system to detect, drive at a speed of 5 km/h or lower during reversing.
- Stop the vehicle immediately a constant alarm sound is heard in case that the vehicle bumps onto the obstacle behind it.
- Do not knock the transducers hard or wash them directly with a high-pressure water gun, otherwise the transducers can be damaged.
- Snow, mud, and water drops on the transducers could cause misoperation.
- Note that the system is likely to fail to detect the following obstacles: those of a conical shape or acute angle reflectors; objects which are prone to absorb sound wave, such as cotton and snow; fine objects such as iron gauze and ropes; objects 30 cm or lower to the ground or 1 m or higher than the ground. The system may detect these obstacles first, but as they become nearer and nearer to the vehicle, they can get out of the effective detection range, not detected as a result.
- When reversing down or up a slope, the system may give out a wrong warning. Remind you to be careful in this situation.
- Note that the system is likely to work abnormally due to wrong induction under the following circumstances: reversing the vehicle on an uneven road, a road paved with round stones, an uphill road or grassland; Interference from ultrasonic noise, metallic sound or high-pressure gas emission sound of the same frequency; sundries on the transducers; Height change of vehicle rear end under heavy load; other detecting equipment installed within the effective detection range.
- If any nonstandard radio communication equipment is installed on the vehicle, usage of such equipment (not including mobile cell phone and audio system) may affect the function of this system.

## Reverse Video Display (if equipped)

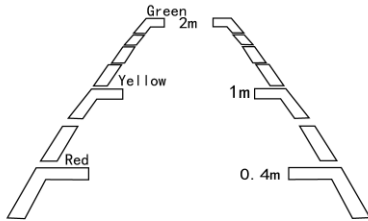

As shown in the figure, if the vehicle is equipped with reversing camera, when the ignition is turned on, the parking brake is released, and the shift lever is engaged in the reverse gear “R” position, the images behind the vehicle, reverse auxiliary lines, and guide lines will appear on the multimedia player.

### Reverse Auxiliary Line

The auxiliary is divided into three sections: red, yellow and green, based on the distance between the object and rear end of the vehicle.

The bottom red line represents the warning line for a distance front the obstacle to the vehicle rear end within 0.4 m; the middle yellow line

represents the warning line for a distance from the obstacle to the vehicle rear end within 1.0 m; the top green line represents the warning line for a distance the obstacle to the vehicle rear end within 2.0 m; the line on both sides is the vehicle width indication line.

### Reverse Guide Line (if equipped)

The yellow auxiliary guide line can develop into a virtual line with dynamic guiding effect according to the rotation of the steering wheel, which helps you to judge the next moving track of the vehicle.

Set the ignition in the OFF position. If the ignition is not set to OFF, a false DTC could be set to memory.

## Fuel

### Recommended Fuel

#### Fuel Suggestions

Fill RON 92 gasoline for vehicle or gasoline with the equivalent standard No., or gasoline with a higher standard No. Using the fuel with an extremely low octane value will reduce power and torque of the engine, and increase the consumed fuel volume.

### Caution

Using fuel of an incorrect grades or filling the fuel tank with incorrect fuel will cause serious damages to the engine and catalytic converter.

Make sure to use the correct fuel that is compatible with your vehicle.

For safety purposes, the fuel tank, pumps and piping must be grounded correctly. Static electricity can ignite fuel vapors. You may be burned and the vehicle will be damaged.

### Caution

Using fuel with low octane could lead to uncontrolled combustion and engine damage. The design of this vehicle does not allow the use of fuel containing methanol. So, do not use fuel containing methanol. Methanol could corrode the metal parts in the fuel system and damage the plastic and rubber parts. Any damage caused by the use of fuel containing methanol is not

(Continued)

**Caution (Continued)**

covered under the warranty. If there is excessive manganese and iron in the fuel, they may block the three-way catalytic converter, cause failure of the spark plugs, and cause other problems. Always use fuel that satisfies the requirements of national standards.

**Do not Use Methyl Alcohol**

Do not use the fuel containing methyl alcohol on the vehicle.

This fuel will reduce the vehicle performance and damage the fuel system components.

**Driving in Other Countries**

When driving your vehicle in other countries:

- Follow all registration and insurance regulations.
- Confirm that the country can provide proper fuel.

**⚠ Danger**

Before refueling, switch off the engine and any external heaters with combustion chambers. Switch off any electronic devices.

Follow the operating and safety instructions of the filling station when refuelling.

If gasoline is spilled on the vehicle, flush the spilled area with clean, cool water as soon as possible. Otherwise, gasoline will damage the paint.

**⚠ Warning**

If a fire starts while you are refueling, do not remove the fill nozzle. Shut off the flow of fuel by shutting off the pump or by notifying the station attendant. Leave the area immediately.

**⚠ Danger**

Fuel is highly flammable and explosive.

(Continued)

**Danger (Continued)**

Smoking is prohibited. No naked flames or sparks allowed. If there is odor of fuel in the vehicle, immediately ask your dealer for inspection and repair.

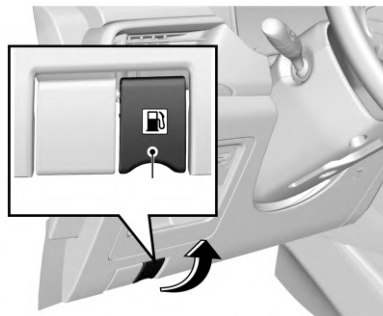
**Filling the Tank**

1. Stop the engine.
2. Pull up the fuel door release handle at the left lower side of the instrument panel to open the fuel door.

If you fail to open the fuel door in the cold weather, you can gently tap the fuel door. Then, try again.

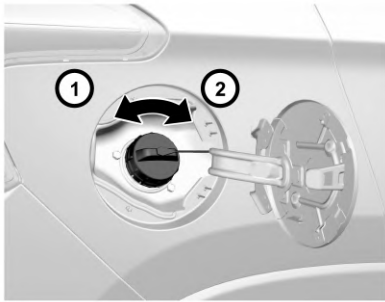

3. Slowly turn the filler cap counterclockwise. If you hear the hissing sound, wait till the sound stops, and then unscrew the cap.
4. Unscrew the filler cap. The filler cap is connected to the fuel door with a sling. Hang the sling to the hanger on the fuel door to secure the filler cap.
5. Reinstall the filler cap after refueling. Turn the filler cap clockwise till clicks are heard.
6. Tightly close the fuel door.



## Vehicle Care

### General Information

Accessories and Modifications .....	128
Vehicle Storage .....	129

### Vehicle Checks

Engine Compartment Overview .....	130
Engine Oil .....	131
Transmission Fluid Life System .....	133
Engine Air Cleaner/Filter .....	133
Engine Coolant .....	133
Washer Fluid .....	134
Brakes .....	135
Brake Fluid .....	135
Wiper Blade Replacement .....	136

### Bulb Replacement

Bulb Replacement .....	137
------------------------	-----

### Electrical System

Fuses .....	142
Engine Compartment Fuse Block .....	143

### Vehicle Tools

Tools .....	145
-------------	-----

### Wheels and Tires

Wheels and Tires .....	145
Winter Tires .....	146
Tire Pressure .....	146

Tread Depth .....	147
Tire Rotation .....	148
Tire Chains .....	148
Tire Repair Kit .....	148
Tire Changing .....	149

### Jump Starting

Jump Starting .....	152
---------------------	-----

### Towing the Vehicle

Towing the Vehicle .....	154
--------------------------	-----

### Appearance Care

Exterior Care .....	156
Interior Care .....	157

## General Information

### Accessories and Modifications

We recommend using original spare and accessory parts and components that are approved by GM to be particularly suitable for the vehicle. GM may not be able to guarantee the compatibility of other products with this vehicle, even if these products meet the specified requirements or are otherwise approved.

For parts of environmental protection, including the engine, transmission, coating, fuel evaporation control device, crankcase emission control device, OBD, ECM, catalytic converter, muffler, EGR (if equipped), supercharger (if equipped) and intercooler (if equipped), it is preferable to use original spare and accessory parts. Otherwise, vehicle emissions may not meet the standard.

GM is not responsible for any problem caused by the use of non-original parts and components (including but not limited to the non-compliance of environmental emissions due to the use of non-original parts and components or other violations of laws and regulations). Without the approval of GM, do not retrofit the electrical system.

Do not retrofit the vehicle. Otherwise, the performance, durability and safety of the vehicle may be affected. Problems caused by retrofitting are not within the scope of warranty.

## Vehicle Storage

Follow this checklist when the vehicle will be in storage for a long time:

### Long-term Storage

- Clean the vehicle for waxing.
- Check the wax coating of engine compartment and the underbody.
- Clean and protect the rubber seal.
- Replace the engine oil.
- Drain the washer fluid reservoir.
- Check coolant anti-freezing agent and corrosion protection.
- Adjust the tire pressure according to the specified value under full load.
- Park the vehicle in a dry and well-ventilated area. Shift to Gear 1 or reverse gear to prevent the vehicle from sliding.
- Close all doors and lock the vehicle.

- Disconnect the clip from the vehicle battery negative terminal. Pay attention to that all systems are turned off.

### Vehicle being Put into Operation again:

- Connect the clip to the vehicle battery negative terminal. Operate the power window to check for proper operation
- Check the tire pressure.
- Fill the washer fluid reservoir.
- Check the engine oil level.
- Check the coolant level.

## Vehicle Checks

### Engine Compartment Overview

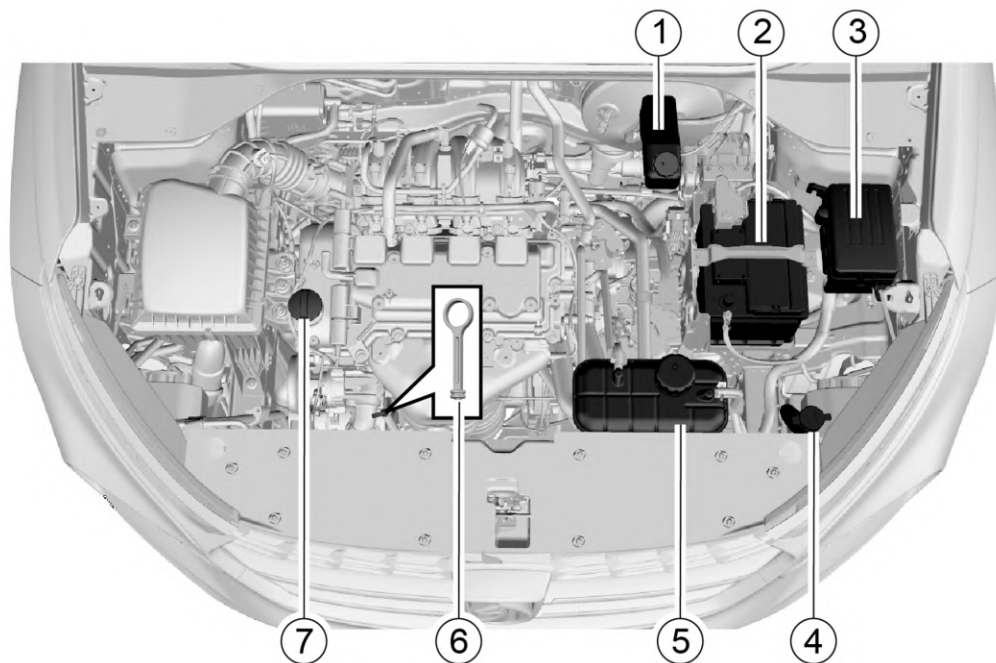

Engine Compartment

1. Brake Fluid/Clutch Fluid Reservoir
2. Battery
3. Fuse Block
4. Washing Fluid Reservoir
5. Engine Coolant Reservoir
6. Engine Oil Dipstick
7. Engine Oil Filling Reservoir

## Engine Oil

Maintain the engine oil at a proper level to ensure correct lubrication of engine.

It is normal that the engine consumes some oil.

Check the engine oil level regularly, e.g. every time parking for refueling.

If the engine oil pressure warning lamp “L” on the instrument panel is on, check the engine oil level immediately.

### Selecting the Right Engine Oil

Selecting the right engine oil depends on both the proper oil specification and viscosity grade.

### Specification

Use full synthetic engine oils that meet the dexos1 specification. Engine oils that have been approved by GM as meeting the dexos1 specification are marked with the dexos1 approved logo. See [www.gmdexos.com](http://www.gmdexos.com).



### Caution

Failure to use the recommended engine oil or equivalent can result in engine damage not covered by the vehicle warranty.

### Engine Oil Level Check

1. Park the vehicle on a horizontal ground.
2. After the engine stops running, wait for a few minutes to have the oil back to the oil pan. For cold engine, the time for the oil returning to the oil pan will be relatively long.
3. Pull out the oil dipstick and clean it.

4. Insert the oil dipstick completely.
5. Pull out the oil dipstick again.

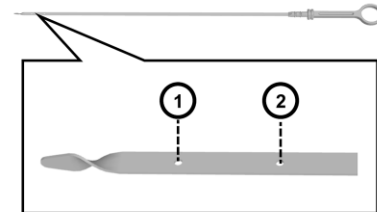

6. Check the engine oil on the dipstick to ensure that the oil is not contaminated.
7. Observe the oil level via the oil dipstick. The oil level should be between the lower limit and the upper limit.
8. If the oil level is lower than the lower limit, add engine oil of the same grade to have the oil level approaching to but not higher than the upper limit. The engine oil fill cap is on the cylinder head cover. See *Engine Compartment Overview* ⇨ 130

 **Warning**

Engine oil is an irritant and, if ingested, can cause illness or death.

- Keep out of reach of children.
- Avoid repeated or prolonged contact with skin.
- Wash exposed areas with soap and water or hand cleaner.

Do not overfill the engine oil. The level should be between the higher upper limit mark and the lower limit mark on the oil dipstick. Excessive engine oil may have adverse effect on the engine, including:

- Increased engine oil consumption
- Oil spilling on spark plug
- A large amount of carbon deposits accumulated on the engine

### Engine Oil and Oil Filter Replacement

The engine oil will lose the lubricating capacity after being contaminated. Be sure to replace the engine oil in accordance with maintenance procedures. The oil filter must be replaced at the same time of engine oil replacement every

time. Under harsh conditions, the replacement interval of engine oil and oil filter must be shorter than the interval specified in standard maintenance procedures.

 **Warning**

An oil change requires professional skills, tools and equipment; therefore, see your dealer. Otherwise, it may cause personal injury or damage to the vehicle.

#### Harsh conditions include but not limited to:

- Frequent cold start.
- Frequent starting and stopping in case of traffic jam.
- Frequent driving for short trips.
- Frequent driving at an outside temperature of below 0 °C.
- Long time idling.
- Frequent driving at low speed.
- Frequent driving under dusty conditions.

### Caution

Engine oil and the oil container are harmful to health.

- Avoid repeated or prolonged contact with engine oil.
- After handling, you must wash your skin with soap and water or hand detergent. Keep this and other types of toxic materials away from children.

Engine oil is an irritant; if ingested, it can cause illness or result in death.

It is prohibited to dispose of old engine oil and filters together with household garbage.

To dispose, make use of local legal waste management facilities.

Old engine oil and filters contain harmful substances that are harmful to human health and threaten the environment.

The use of non-specified or poor quality engine oil or additives will cause damage to the engine.

See your dealer before attempting to use additives.

## Transmission Fluid Life System

### Transmission Fluid Leakage Check

This work requires professional skills and equipment. To avoid personal injury or vehicle damage, see your dealer.

### Engine Air Cleaner/Filter

Check and replace the air filter element regularly according to the maintenance instructions in this manual.

### Air Filter Cleaning

If the air filter element is too dirty, clean it:

1. Shake the air filter element to remove floating dust.
2. Clean the interior of air filter housing.
3. Cover the filter housing with a wet cloth when cleaning the filter element.
4. Clean the filter element with compressed air in the opposite direction of the engine intake.

Clean air is necessary for the normal operation of engine.

Do not drive the vehicle without the air filter element installed. Otherwise, the engine will be damaged.

### Engine Coolant

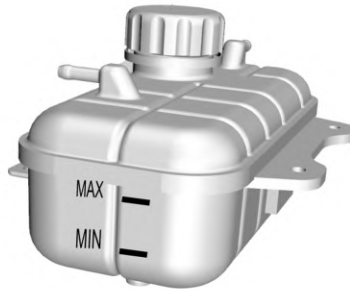

The vehicle cooling system is filled with ethylene glycol coolant.

This kind of coolant in right mixing ratio can provide excellent anti-corrosion and anti-freezing performance for the cooling and heating systems.

When the engine is in a cold state, the coolant level should be between MIN (minimum) and MAX (maximum) marked on the coolant tank. The coolant level rises with the engine temperature rise and drops as the engine cools.

If the coolant level is lower than the MIN (minimum) mark, see your dealer for coolant filling or replacement.

Use a 50/50 mixture of clean, drinkable water and DEX-COOL coolant.

#### Warning

Scalding hot coolant steam could be blown out under pressure, which could cause serious injury.

Never remove the coolant reservoir cap when the engine and radiator are hot.

#### Warning

Engine coolant is a dangerous substance.

- Avoid repeated or prolonged exposure to coolant.

(Continued)

**Warning (Continued)**

- In case of contact with coolant, wash skin and fingernails with soap and water.
- Keep it out of reach of children.
- Coolant is irritating to the skin and can cause illness or death if swallowed.

**Washer Fluid**

Before driving, check the volume of washing liquid in windshield washer fluid reservoir. In cold weather, the windshield washer solvent container cannot be overfilled.

Washer solvent will swell under low temperature due to freezing. An overfull container has no enough space for expansion, thus resulting in damages.

See your dealer for filling of the correct washer solvent.

**Caution**

- Do not use washer fluid that contains any type of water repellent coating. This can cause the wiper blades to chatter or skip.
- Do not use engine coolant (antifreeze) in the windshield washer. It can damage the windshield washer system and paint.
- Do not mix water with ready-to-use washer fluid. Water can cause the solution to freeze and damage the washer fluid tank and other parts of the washer system.
- When using concentrated washer fluid, follow the manufacturer instructions for adding water.

(Continued)

**Caution (Continued)**

- Fill the washer fluid tank only three-quarters full when it is very cold. This allows for fluid expansion if freezing occurs, which could damage the tank if it is completely full.

When adding windshield washer solvent, it is suggested to use the ready-to-use special washer solvent. If concentrated washer solvent is used, add water to dilute it according to the manufacture's instructions.

Do not use tap water. Minerals or impurities contained in tap water may block lines of the windshield washer. If the temperature is likely to fall below freezing point, use windshield washer solvent with a good anti-freezing performance.

If the temperature is likely to fall below freezing point, use windshield washer solvent with good anti-freezing performance.

## Brakes

### Brake Pedal Travel Check

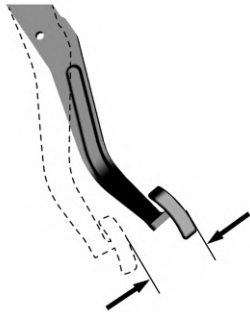

#### Brake pedal travel:

To avoid affecting the pedal travel, do not lay a thick carpet in the brake pedal area.

The reasonable range of brake pedal free travel is 0–30 mm.

If the brake pedal fails to return or the brake pedal travel becomes longer, see your dealer for inspection. This may indicate a fault in the brake system.

## Brake Fluid

There is a brake reservoir on the vehicle. The brake fluid is moisture-absorbing, and the fluid with excessive water content will reduce the efficiency of the hydraulic brake/clutch system. Replace the fluid as per the instruction in the Manual to avoid corrosion of the hydraulic system.

Be sure to use the brake fluid recommended by General Motors. Add fluid into the reservoir to reach a proper level. The fluid level should not be lower than the MIN (minimum) mark or higher than the MAX (maximum) mark.

The cause of excessive low brake fluid level may be leakage of brake system or normal wear of the brake pad/lining. See your dealer to determine whether the system needs to be repaired. If repairs are necessary, add fluid after repair of the hydraulic braking system. When the brake fluid level is lower than the lower limit, the braking system warning lamp (ⓘ) will be on. See *Brake System Warning Light* ⇨ 61



### Adding Brake/Clutch Fluid

1. Thoroughly wipe off the dirt around the reservoir fill cap.
2. Open the fill cap.
3. Add the brake/clutch fluid recommended by General Motors to reach the MAX (maximum) mark. Be careful not to spill the fluid on the paint surface. In case of spilling on the paint surface, wash the area with cold water immediately.
4. Install the reservoir fill cap.



Before opening the fill cap, clean the area around the brake/clutch fluid reservoir fill cap. Contamination of the brake/clutch fluid system will affect the system performance, resulting in costly repairs.

### Caution

The brake/clutch fluid is an irritant to skin and eyes.

- Do not let brake/clutch fluid come into contact with your skin or eyes. If you do, wash the affected area with soap and water or hand detergent.

### Caution

- Do not dispose used brake/ clutch fluid as regular waste.
- Make sure to use the authorized local waste management organizations.

Used brake/clutch fluid and containers are hazardous. They are harmful to health and the environment.

### Caution

An overflow of brake/clutch fluid on the engine may cause the fluid to burn.

Do not overfill the reservoir.

An engine fire can cause personal injuries and damage your vehicle and other property.

## Wiper Blade Replacement

Foreign objects on the windshield and blade will reduce the effectiveness of the wiper. If the blade does not work properly, wipe the windshield and the blade with special or neutral washer solvent. Flush with water thoroughly. If necessary, repeat the above operation. Do not wipe the windshield with corrosive substances or materials that cannot be removed from the glass (e.g. silicone).

The strips have a layer of graphite on the surface for lubrication and protection. It should be protected from excessive wiping and undue polishing.

Do not start the wiper when the windshield surface is dry. Park the vehicle in a cool place as far as possible to prevent exposure to high-temperature, which will accelerate the aging and deformation of strips.

Remove foreign matters such as bird droppings, dust and leaves from the windshield surface before starting the wiper; otherwise, the service life of blades will be reduced.

### Wiper Blade Removal and Installation

Fold the wiper arm on the windshield for operation.

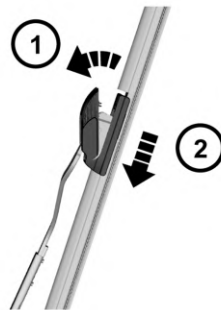

Front Wiper

Remove the wiper blade as follows:

1. Open the trim cover of the wiper blade in the direction of arrow (1).
2. Push the blade in the direction of arrow (2) to separate the blade from the hanging arm.

Follow the reverse steps during installation to fasten the trim cover.



**Rear Wiper**

As shown, adjust the wiper blade to an angle perpendicular to the wiper arm, and then press the blade in the direction of the arrow to separate the blade from the wiper arm.

Do the opposite steps to install the wiper blade.

When removing the rear wiper blade, pull the wiper blade out from the mounting point on the wiper arm. When installing, press the wiper mounting point in the direction of the arrow as shown in the figure.

## Bulb Replacement

### Caution

Halogen bulbs contain pressurized gas. Always handle halogen bulbs with care, and dispose them properly.

- Wear eye protection when working with the bulbs.
- Protect the bulbs from abrasion and scratches.
- When the bulb is illuminated and not in a sealed installation, protect it from contact with liquids.
- Illuminate the bulb only after it has been installed in a lamp holder.
- Replace any headlamp that is cracked or damaged.

(Continued)

### Caution (Continued)

- Do not touch the replacement bulb with your bare fingers.
- Keep the bulbs away from children.
- Dispose used bulbs with care. Otherwise the bulbs may explode.

### Caution

- Clean halogen bulbs with alcohol or mineral spirits and a non-woven cloth. Do not touch the bulbs with your bare hands.

Fingerprints on a halogen bulb can significantly shorten the bulb's effective lifespan.

### Caution

The replacement of any bulb may require professional skills and special equipment. It is recommended to have the replacement done by your dealer.

(Continued)

**Caution (Continued)**

Improper installation may cause personal injury or vehicle damage.

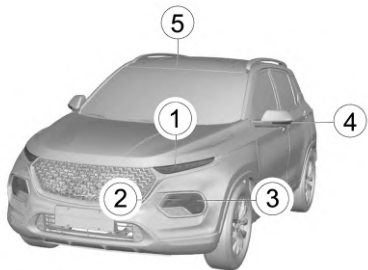

### Configuration 1

Callout	Lamp Bulb	Power x quantity	Remarks
1	Daytime running lamp/position lamp	LED	
2	High/low beam	60W×2	HB3
3	Front turn signal lamp	21W×2	PY21W
4	Side Turn Signal Lamp	LED	
5	Front Reading Lamp	5W×1	C5W
6	Rear brake lamp/position lamp	LED	
7	Rear turn signal lamp	16W×2	WY16W
8	Reversing lamps	16W×2	W16W
9	High Mount Stop Lamp	LED	
10	Rear License Plate Lamp	5W×2	W5W
11	Rear fog lamp	LED	
12	Trunk compartment lamp	LED	Inside the luggage compartment

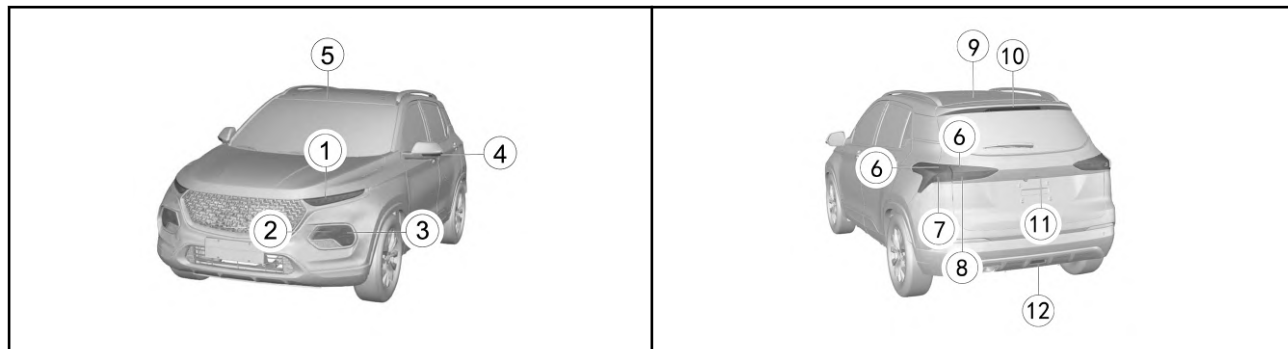

Configuration 2

Callout	Lamp Bulb	Power x quantity	Remarks
1	Daytime running lamp/position lamp	LED	
2	High/low beam	LED	
3	Front turn signal lamp	LED	
4	Side Turn Signal Lamp	LED	
5	Front Reading Lamp	5W×1	C5W

Callout	Lamp Bulb	Power x quantity	Remarks
6	Rear brake lamp/position lamp	LED	
7	Rear turn signal lamp	16W×2	WY16W
8	Reversing lamps	16W×2	W5W
9	Rear Reading Lamp	5W×1	C5W
10	High Mount Stop Lamp	LED	
11	Rear License Plate Lamp	5W×2	W5W
12	Rear fog lamp	LED	
13	Trunk compartment lamp	LED	Inside the luggage compartment

## Electrical System

### Fuses

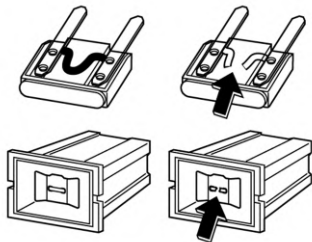

#### Fuse replacement:

1. Open the fuse box cover.
2. Identify damaged fuses by finding out blown fuses.
3. Use a fuse extractor to remove the blown fuses. The fuse extractor is in the engine compartment fuse box.

#### Warning

Installation or use of fuses that do not meet GM's original fuse specifications is dangerous. The fuses could fail, and result in a fire. You or others could be injured or killed, and the vehicle could be damaged.

#### Caution

Never remove blown fuses with conductive tools. Always use the fuse puller. Use of metal and other conductors can cause a short circuit, electrical system damage or a fire. Thus it may cause serious personal injury.

4. Figure out the cause of fusing and remove the fault.
5. Install new fuses with rated current meeting the requirements.

#### Caution

Use of fuse alternatives or a fuse of the wrong type or rating can damage the electrical system and lead to a fire.

Always use fuses of correct type and rating, meeting specifications.

An engine on fire could injure you and damage the vehicle and other properties.



#### Indoor Fuse Box

The indoor fuse box is on the lower left side of the instrument panel and it can be seen after pulling out the storage box.

**Caution**

Never remove blown fuses with conductive tools. Always use the fuse puller. Use of metal and other conductors can cause a short circuit, electrical system damage or a fire. Thus it may cause serious personal injury.

**Caution**

Using a fuse substitute or a fuse of the wrong type or rating can damage the electrical system or even start a fire.

Use only a specified fuse and do not use a different type or rating other than specified in this manual.

Such use can result in personal injuries or damage to your vehicle or other property.

**Engine Compartment Fuse Block**

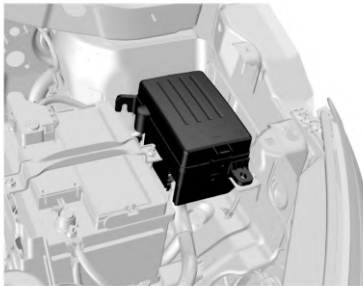

**Engine Compartment Fuse Box**

The engine compartment fuse box is next to the battery.

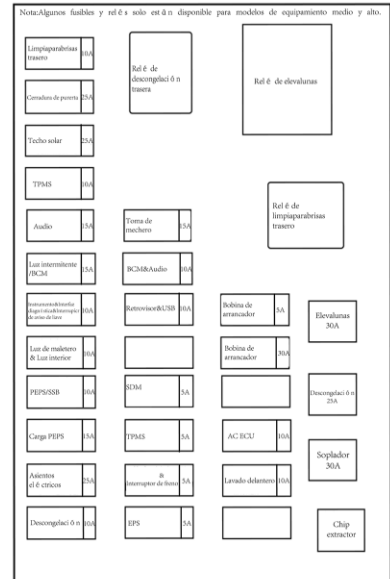

**Indoor Fuse Box**



For vehicles with different models or configurations, the layout of fuse box internal components may be different. The owner's actual vehicle shall prevail.

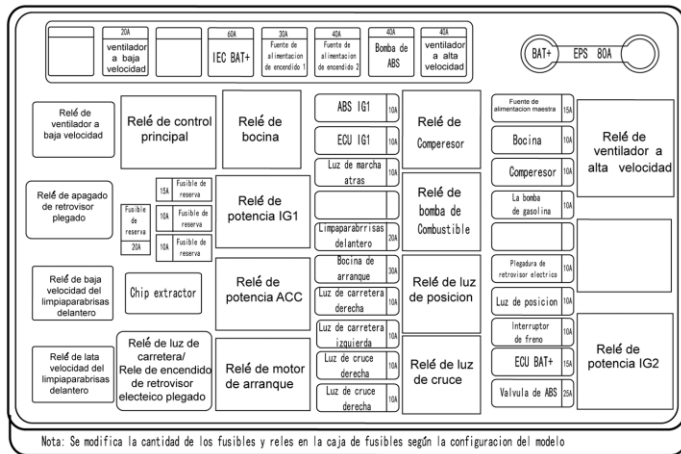

### Engine Compartment Fuse Box

For vehicles with different models or configurations, the layout of fuse box internal components may be different. The owner's actual vehicle shall prevail.

## Vehicle Tools

### Tools

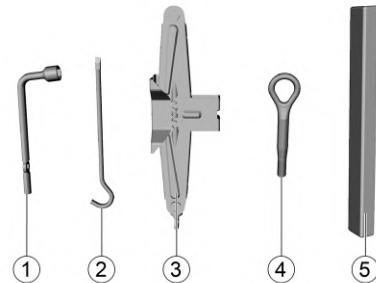

1. Wheel Nut Wrench
2. Jack Rocker
3. Jack
4. Towing Hook
5. Warning Triangle

## Wheels and Tires

Original tires guarantee optimum matching of riding comfort, tread life and performance.

### Caution

When replacing wheels and tires make sure you use wheels and/or tires of correct specifications. The use of wheels and/or tires of other specifications may result in abnormal operation of ABS and other relevant components and even cause a crash.

See your dealer before replacing original tires or wheels.

Failure to do so may cause personal injury and damage the vehicle or other properties.

### Tire and Wheel Maintenance

Running over sharp objects may damage tires and wheels.

If you have to run over these objects, slow down. Do not touch the curb when parking.

### Regular Tire Check

Including appearance damage, foreign objects, punctures, cuts, cracks, side wall bumps, etc.

Inspect the wheel for damage.

Tire defects including the above defects may lead to vehicle out of control, causing personal injury.

In case of damage or abnormal wear of tire or wheel, see your dealer.

The vehicle is equipped with radial tires. General Motors suggests replacing with radial tires of the same size, pattern, tread wear, temperature and rated speed.

The use of tires with different size than the original tires may cause the tire and the vehicle component to interfere with each other, thus causing damage to the tire and vehicle.

If the vehicle is equipped with tire pressure monitoring system, the tire repairing liquid for tire repair may result in the failure of the tire pressure monitoring system sensor. See your dealer.

### Winter Tires

The use of winter tires while driving on icy and snowy roads can improve driving safety. It is suggested to replace with winter tires when the temperature is below 7°C. Select winter tires with radial tire structure and use such winter tires on all four wheels. Use the specified tire pressure. Do not drive the vehicle at a speed

exceeding the maximum speed specified by the tire manufacturer. All-weather tires can be used except winter tires.

### Tire Pressure

The tire pressure must meet provisions of the manual to ensure optimum matching of driving comfort, safety and driveability.

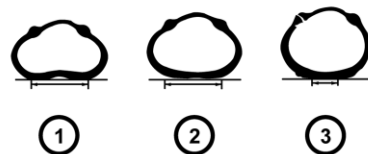

1. Low Pressure
2. Comfortable Pressure
3. Over Inflation Pressure

Refer to the tire load information label for the correct tire pressure. The label is on the sill plate below the driver side door. At the time of cold

start, check the tire pressure with an accurate tire pressure gauge. After check of tire pressure, tighten the valve core cap.

Make sure to check the tire pressure at the time of cold start. The reading measured after the tire temperature has increased shall not prevail. Tires will become hot after traveling for 1.6 km and will not cool down completely within three hours after stopping.

Check the tire pressure each time when refueling or at least every month. Incorrect tire pressure may:

- Increase tire wear.
- Affect the vehicle manoeuvrability and safety.
- Affect the riding comfort.
- Reduce the fuel economy.

Excessively low tire pressure will cause overheat of the tire, leading to internal damage and layered tread and even tire burst when driving at a high speed. Even if the tire pressure was adjusted later, driving under too low pressure may have damaged the tire.

Vehicle overload is prohibited.

Be sure to keep a proper tire inflation pressure.

Be sure to check the tire inflation pressure at the time of cold start (ambient temperature).

## Tread Depth

Check the tire tread depth as per the tread wear indicator regularly. The mark on the tire wall indicates the position of the tread wear indicator.

Be sure to dispose of scrapped tires in accordance with local environmental regulations.

### Caution

Do not drive the vehicle in case of tire wear or damage. Worn or damaged tires may cause the vehicle to go out of control and cause a crash, resulting in personal injury and damage to the vehicle or other property.

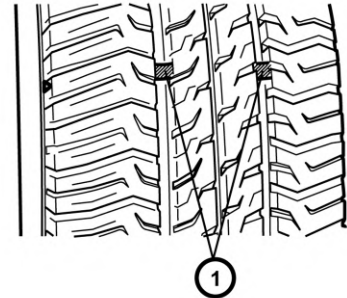

The tire must be replaced when the tread wear indicator appears. When the tread depth is equal to or less than 1.6 mm due to wear, the tread wear indicator will appear between the tread grooves.

## Tire Rotation

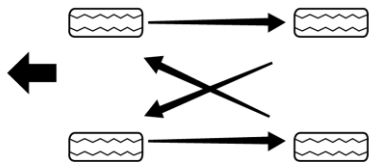

The front tires and the rear tires have different functions and therefore have different levels of wear.

The front tires wear faster than the rear tires. In order to prolong the tire life and avoid uneven tread wear:

1. Inspect and replace the tire according to the Maintenance and Warranty Manuals on schedule.
2. Keep a proper tire pressure.
3. Check nuts/bolts for tightening.

If the vehicle is equipped with tire pressure monitoring system, after tire rotation or tire replacement, see your dealer to relearn the tire pressure.

### Caution

Using the wrong replacement wheels or wheel bolts on your vehicle can be dangerous. It could affect the braking and handling of the vehicle, make the tires lose air and make you lose control of the vehicle. You could have a crash in which you or others could be injured. Always use the correct wheel and wheel bolts for replacement.

## Tire Chains

Tire chains are only used for emergencies or in areas clearly defined by law and should be installed on the drive wheels. Be especially careful when driving the vehicle equipped with tire chains. Compared with tires without tire chains, when tires are installed with tire chains, the maneuverability of the vehicle is poor, and the tire chain may damage the vehicle tire, suspension or vehicle body. Therefore, use cable tire chains as far as possible to ensure

enough space between the tire and other parts in the wheel casing. When using tire chains, carefully read the installation and other related instructions of the tire chain manufacturer.

After installation of tire chains, it is suggested to drive the vehicle at the speed of below 30 km/h or the limited speed recommended by the tire chain manufacturer (whichever is smaller).

## Tire Repair Kit

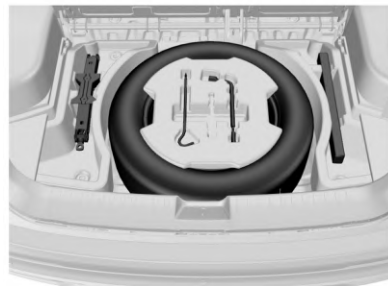

The spare tire, jack and tools are under the luggage compartment and can be seen after raising the luggage compartment floor. In-vehicle tools include jack rocker, socket wrench, screwdriver (if equipped).

## Spare Tire

Although the spare tire has been inflated, it will leak after a period of time. The inflation pressure shall be checked regularly.

Refer to the tire load information label for the correct inflation pressure.

Do not use your spare tire for other vehicles. Do not mix your spare tires or wheels with wheels or tires of other vehicles since they are not matched. Your spare tire should be put together with its wheel.

### Note

Do not use tire chains on spare tires. They may not be suitable for spare tires and can damage to your vehicle.

## Tire Changing

### Safety Precaution of Tire Replacement:

1. Hazard warning lamp ON.
2. Drive off the highway to a safe place and stay away from traffic.
3. Park the vehicle on a flat and hard surface where the vehicle will not slip. Take out the warning triangle and place it at a proper position behind the vehicle.

4. Turn off the engine and remove the key.
5. Pull the shift lever to the first or reverse gear and tighten the parking brake.
6. Have all passengers leave the vehicle and stand in a safe place.
7. Secure the tire that is diagonal to the tire that need to be replaced with wedges, blocks or stones.

Failure to comply with these safety precautions may cause your vehicle to slip off the jack, thus causing serious injury.

### Take out the Spare Tires

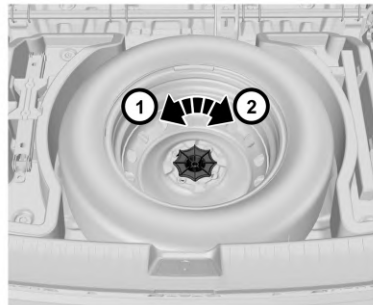

1. Open the liftgate and remove luggage compartment floor. The floor hook can be hung on the hinge on the right side of the liftgate.
2. Take out the tool bracket on the spare tire.
3. Rotate the butterfly nut in the center of the spare tire counterclockwise to remove it, and then place it properly.
4. Take out the spare tires. Place the spare tire at the vehicle bottom near the wheel to be replaced so as to prevent the vehicle from suddenly falling.

Do not remove any nut before wheels are lifted off the ground.

## Tire replacement



1. Use a socket wrench to unscrew the wheel nut by one turn.

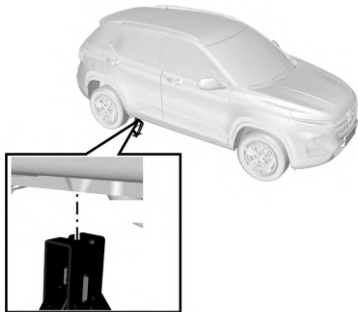

2. As shown in the figure, the flanges on the lower part of the vehicle side have triangular marks on the front and rear sides, representing the lifting position of the point.
3. Place the jack just under the triangle mark closest to the tire that needs to be replaced. Align the slot on the jack head with the edge fold.

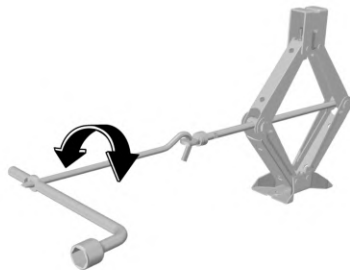

4. Connect the wheel nut wrench and jack rocker to the jack as shown.



5. Rotate the jack rocker clockwise to allow the jack to rise slowly and ensure that the jack head is firmly pushed into the lifting position.

Do not attempt to lift the vehicle before the jack is put into a proper position. The jack should be firmly secured between the vehicle and the ground.

6. After ensuring that the jack is in the correct position, continue turning the socket wrench until the tire is about 3 cm off the ground.
7. Turn counterclockwise to completely remove the wheel nut.
8. Remove the wheel to be replaced.

9. Install the spare tire on wheel hub.
10. Install all wheel nuts and tighten them initially.
11. Rotate the jack rocker counterclockwise to lower the vehicle to the ground stably.

When the jack is lifting the vehicle, ensure that jack is properly placed without being slippery.

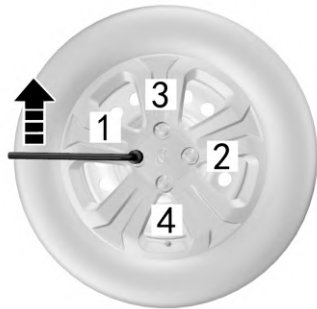

12. Tighten the wheel nut according to the sequence of 1-2-3-4 above. The torque value is 90–100 Nm for the iron wheel and 100–130 Nm for the aluminum alloy wheel.
13. Put the flat tire in the spare tire storage location and secure it properly.

14. Put tools back in the tool kit and secure them.

### Caution

Never use oil or grease on wheel nuts.

Always use correct wheel nuts.

As soon as possible, take your car to a dealer and have the wheel nuts tightened according to specifications.

If tightened incorrectly, the nuts might come loose.

### Caution

Incorrect wheel nuts or improperly tightened wheel nuts can cause the wheel to come loose and even come off. This could lead to a crash. Be sure to use the correct wheel nuts. If you have to replace them, be sure to get new original equipment wheel nuts. Stop somewhere as soon as you can and have the nuts tightened with a torque wrench to the proper torque specification. See “Capacities and Specifications” in the Index for wheel nut torque specification.

### Caution

When using the jack, the vehicle could become unstable and move, damaging the vehicle and causing personal injury.

- Use the jack supplied at the correct jacking position.
- When installing the jack for lifting the vehicle, it should be perpendicular to the ground.
- Do not go under a jacked-up vehicle.
- Do not start the vehicle while it is jacked-up.
- Before jacking, get all passengers out of the vehicle and clear of the vehicle and other traffic.
- Use the jack only for changing wheels.
- Do not jack the vehicle on an inclined or slippery surface.
- Use the jacking position nearest to the wheel requiring changing.
- Block the wheel diagonally opposite the wheel to be changed.

(Continued)



**Caution (Continued)**

- Before jacking, ensure the parking brake is on and the shift lever is in 1 (First) or R (Reverse).
- Do not jack the vehicle and change the wheel near traffic.

Do not place jacks and tools in the passenger compartment. In the case of emergency stop or collision, unfixed equipment may fly in the vehicle and harm the passenger.

When the vehicle jacking condition is unsatisfactory or if you do not have the confidence to safely complete this work, see your dealer.

**Caution**

Getting under a vehicle when it is jacked up is dangerous. If the vehicle slips off the jack you could be badly injured or killed. Never get under a vehicle when it is supported only by a jack.

**Jump Starting**

The vehicle with a low battery can be started by using the battery of other vehicles by the means of jump start.

If the battery is dead, see your dealer unless you can confirm that you have enough electrical knowledge that you can safely complete this work.

**Preparation before Jump Start**

1. Pull up the parking brake.
2. Ensure that the gearshift lever is at the N (Neutral) or P (Park) position.
3. Turn off all electrical accessories.

Turn off the audio system before jump start of the vehicle. Otherwise, the audio system will be damaged.

Turn off unnecessary electrical devices when the vehicle is running at a low speed for long periods of time.

**Caution**

Batteries carry a risk of explosion. You may be burned by the battery acid, and a short circuit may lead to personnel injuries and damages to your vehicle.

- Keep batteries away from flames and sparks.
- Do not lean over the battery while jump starting the vehicle.
- Do not let the cable terminals contact each other.
- Wear eye protection when working near the batteries.
- Do not let battery acid come into contact with your eyes and skin, fabrics, and painted surfaces.
- Make sure that the battery to be use for the jump start has the same voltage rating as that of the drained battery.
- Do not disconnect the drained battery from the vehicle.

(Continued)

**Caution (Continued)**

Failure to observe the above cautions or the instructions below may result in battery explosion, burning by battery acid or short circuits. This can cause damages to the electrical systems of both vehicles and result in serious personnel injuries.

 **Warning**

Always route jumper cables so they cannot catch on rotating parts in the engine compartment.

Otherwise you may damage the vehicle and cause serious injury.

**Caution**

Do not start the vehicle by pushing or dragging. Doing so may damage the catalytic converter, the transmission or even cause personal injury.

**Jumper Cable Connection**

When jump starting a vehicle, connect the jumper cable in the following order:

1. Clip one end of the first jumper cable to the positive terminal of the powered battery. (There is a "+" mark on the battery housing or the terminal)
2. Clip the other end of the jumper cable to the positive terminal of the dead battery. (There is a "+" mark on the terminal)
3. Clip one end of the second jumper cable to the negative terminal of the powered battery. (There is a "-" mark on the battery housing or the terminal)
4. Select the ground contact away from the battery on the unpowered vehicle, such as the steel bolts of the engine bracket. Connect the other end of the second cable to the ground contact.
5. While jump starting, start the engine of the vehicle providing the jump start power supply. Try to start the engine of the vehicle that has no electricity within one minute, and do not turn the ignition key more than five seconds each time. After starting, keep the rotation speed at 2000 rpm for several minutes

6. Remove the jumper cable carefully in reverse order, remove the negative cable first and then the positive cable.

Do not use the battery as a jump source for other appliances for a long time. Otherwise, it is easy to make the battery lose electricity and may even cause safety accidents.

 **Warning**

The last connection to the vehicle to be charged should NOT be made to the negative (-) battery terminal.

Attach the clamp for this last connection to a steel bracket bolted to the engine block.

This last connection should be as far away from the battery as possible.

Connecting the jumper cable to the negative terminal of the discharged battery could result in arcing and possibly a battery explosion.

Serious personal injury or vehicle damage can result.

## Towing the Vehicle

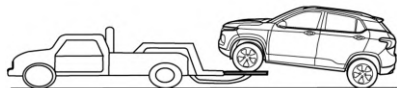

If vehicle towing is necessary, see your dealer or a professional towing service.

Do not tow the vehicle with lifting chain type equipment. It must use plates or wheel lifting equipment.

### Caution

- Never allow passengers to sit in the vehicle being towed.
- Never allow the towing speed to exceed the safety speed or posted speed limit.

(Continued)

### Caution (Continued)

- Never use damaged parts not fully and firmly secured to the vehicle to tow. Failing to observe the above precautions could lead to personal injury.

### Vehicle Traction with Wheel Lifter



1. Turn on the hazard warning flasher.
2. Turn the ignition to ACC position.
3. The transmission must be in neutral gear.
4. Release the park brake.
5. Front wheels must be off the ground when towing.

### Vehicle Traction with Platform Trailer

When towing the vehicle with a platform trailer, turn off the ignition and check that the vehicle is firmly attached to the trailer.

If the vehicle must be towed from the rear, use traction device supporting wheels under the front wheels. The front wheels should not be on the ground when the vehicle is towed from the rear. Otherwise, it may cause serious damage to the vehicle transmission.

### Emergency Trailer

If a tractor is not available in case of an emergency, it can secure the rope on the front towing hook under the vehicle for temporary vehicle towing. When the vehicle is towed via the front towing hook, only a traction rope can be used. Do not use a rigid tow bar.

No matter manual transmission or automatic transmission, engage the neutral (N) gear and release the hand brake when the vehicle is towed.

### Notes on AT Model Traction

If the automatic transmission is faulty, the neutral (N) gear may not be engaged. In this case, if vehicle traction is required, the

drive shafts of the two front wheels should be removed first; otherwise, the transmission may be damaged.

See your dealer.

### Front Towing Hook

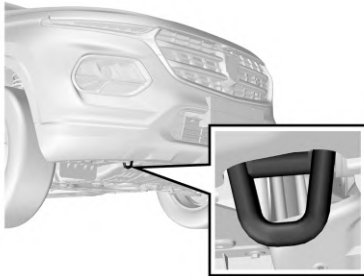

**Type-I**

As shown, the trailer is hooked under the chassis at the front of the vehicle to ensure that the rope is securely installed before towing.

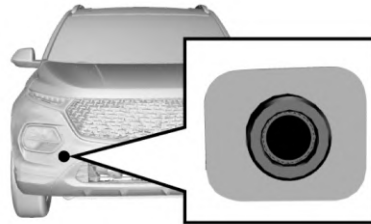

**Type-II**

The front towing hook of some models has a hole cover on the right side of the bumper, and the fixing hole for installing the towing hook can be seen by opening the hole cover. Place the towing hook in the tool bag of the luggage compartment. Take out the towing hook and install it into the fixing hole. Rotate the towing hook clockwise to tighten it completely and insert a socket wrench into the hook hole to assist tightening. Be sure that the towing hook is installed firmly before towing the vehicle.

When towing the vehicle, the driver must control steering and braking in the vehicle.

After towing, remove the rope and tow hook, close the hole cover, and put the tow hook back into the tool box.

The vehicle may be damaged when it is towed by ropes. To reduce damage.

- The towing hook must be used when other traction devices are not available.
- The vehicle shall be towed from the front only.
- Keep the traction rope out of contact with the bumper.
- Make sure that both ends of the traction rope are firmly secured on the towing hook.
- Pull the traction rope for inspection.
- Drive the vehicle at a low speed and avoid sharp turning.

The vehicle may be out of control when it is towed by ropes. To reduce damage.

- The towing distance shall not be too long, and the vehicle should be towed at a low speed.
- Do not tow the vehicle if the wheel, transmission, axle, steering or brake is damaged.

- Do not remove the key from the ignition. Otherwise, the steering will be locked so that the vehicle cannot turn.

The towing speed shall not exceed 30 km/h, and the towing distance shall not exceed 40 km.

When long-distance towing is required, it is suggested to see your dealer or a professional towing service company for help.

## Appearance Care

### Exterior Care

#### Vehicle Washing

The best way to maintain the finish paint of vehicles is to wash it regularly and keep it clean.

- Park the vehicle in the place where is not directly exposed to sunlight.
- Wash the vehicle with the specified neutral soap liquid and cold or warm water.
- Be sure to remove the soap liquid and cleaning agent from the surface by the means of flushing.

General Motors vehicles are designed to operate under normal environmental conditions and natural factors.

Do not use household dish washing detergent to wash the vehicle. The dish washing detergent can wash off paint and wax.

Avoid excessive vehicle washing pressure. Water may enter the vehicle and damage the interior.

#### Polishing and Waxing

Regular polishing can remove residues from the surface of the vehicle. After polishing, use high-quality car wax for protection.

Do not clean or polish aluminum trim with automotive or chrome polishing agent, steam, or alkaline soap liquids.

These substances are abrasive and may damage trim and wheels.

#### Exterior Bright Metal Parts Protection

Clean the bright metal trims regularly. It is usually washed with water. When waxing the vehicle, also wax these bright metal parts.

#### Aluminum Wheels and Wheel Trim Cover Cleaning

To maintain the original appearance of the wheel and wheel trim cover (if any), do not allow them to collect dust or brake dust.

Clean the wheel/wheel trim cover regularly. Do not use abrasive cleaning agent or brush that may damage the finish paint.

Do not use abrasive cleaning agent or brush to clean aluminum wheels or wheel trim covers.

#### Front Windshield Outside Cleaning

Waxes or other materials on the front windshield and blade may cause the blade to shake when working. Moreover, such foreign matters are not conducive to keeping the front windshield clean. Clean the outside of the front windshield regularly with a non-abrasive cleaning agent.

Water does not form water droplets on the clean front windshield.

Decals will affect the rear windshield defroster. Do not paste decals on the inner side of the rear windshield. Otherwise, it will affect the driver's vision.

#### Corrosion Prevention

General Motors vehicles are designed to have anti-corrosion capabilities. The use of special materials and protective paint on most vehicle parts helps maintain satisfactory appearance, strength and reliability.

Although the surfaces of certain parts inside the engine compartment or of the underbody may rust, the reliability or performance of these parts will not be affected.

### **Metal Plate Damage**

If the body needs to be repaired or replaced, ensure that the repair shop uses proper anti-corrosion materials to restore the anti-corrosion protection performance.

### **Foreign Matter Deposition**

The following substances may damage the paint surface:

- Calcium chloride and other salts
- Ice melting agent
- Road surface oil and asphalt
- Sap
- Bird droppings
- Industrial dust

Remove harmful substances on the vehicle in time. If residues cannot be removed with soap liquid, a special cleaning agent can be used.

### **Finish Paint Damage**

Repair the gravel scratches, cracks or deep scratches on the finish paint as soon as possible. Exposed metal is prone to corrosion. Quick-drying products can be used to repair tiny cracks and scratches. Body and paint repair shops can complete large-scale repairs.

Only safe cleaning agents that are harmless to the paint surface can be used.

Other cleaning agents may permanently damage the paint.

### **Underbody Maintenance**

Corrosive substances used for ice and snow melting and dust prevention may accumulate at the underbody. Failure to remove these substances will accelerate corrosion and rusting.

Flush the underbody with clean water regularly. Clean the part where the mud is prone to accumulate carefully. Loosen the accumulated dirt in the enclosed area before flushing with water.

When necessary, see your dealer for service.

## **Interior Care**

### **Cleaning Agent**

The manufacturer's suggestions must be observed when using cleaning agent or other chemical products inside or outside the vehicle.

Do not use dangerous cleaning agent when cleaning the interior and exterior of the vehicle. For example:

- Acetone
- Paint diluent
- Porcelain glaze reducing agent
- Nail polish remover

When cleaning the interior and exterior of the vehicle, the following cleaning agents are prohibited unless special instructions for cleaning stains are included in the fabric cleaning tips:

- Laundry soap
- Bleaching powder
- Reducing agent

**Caution**

Many cleaning agents may be hazardous or flammable or may cause injury or damage your vehicle too. So when cleaning finish parts do not use volatile solvents such as acetone, paint thinner, bleach, or reducing agents. Never use gasoline for cleaning purposes.

Do not use the following materials for cleaning:

- Carbon tetrachloride
- Gasoline
- Benzene
- Naphtha

When using any cleaning agent or other chemical products inside the vehicle, open the doors for proper ventilation.

To avoid permanent color change of light-colored interior trims, do not allow the easy-to-discolor fabrics to come into contact with the seat liner unless both materials are completely dry. Fabrics with easy-to-discolor materials are:

- Casual clothes
- Dyed denim

- Leather
- Kidskin
- Newspapers and decorative paper

**Caution**

Avoid prolonged exposure to vapors of cleaners and other chemicals. These vapors are hazardous and harmful to health, especially in restricted and poorly ventilated spaces.

Clean the interior and exterior of the vehicle with proper cleaning methods and materials.

Use a vacuum cleaner or a banister brush to remove dust and scum that accumulate on the fabric inside the vehicle frequently.

Wipe the vinyl plastics and leather trims regularly with a clean wet cloth.

Remove dust, spots or stains on trims with a suitable cleaning agent.

Clean the interior trims of the vehicle with proper cleaning methods and materials. Otherwise, it will produce water spots, watermarks and permanent spots, especially during the first washing. These substances will permanently damage the vehicle.

**Seat Belt Maintenance**

Keep the seat belts clean and dry. Prevent seat belts from being contaminated by polishing agents, oils and chemical products, especially battery fluid, bleaching powder or dyestuff. These contaminants will reduce the strength of the seat belt material. Check all seat belt parts regularly.

Replace any damaged seat belt or part immediately.

The seat belt or related parts that are stretched during the accident must be replaced, even if the damage is not obvious or is not visible. The seat belt for replacement must be new.

General Motors suggests replacing the whole seat belt assembly after a crash. It is not necessary to replace the seat belt after it is checked to be undamaged and normal by your dealer.

The seat belt must be kept in good working condition to maintain its normal function.

**Glass Surface**

Make sure that the window glass is clean, which helps reduce glare and improve vision.

## Service and Maintenance

### General Information

Maintenance .....159

### Maintenance Schedule

Maintenance Schedule .....159

### Multi-Point Vehicle Inspection (MPVI)

Multi-Point Vehicle Inspection (MPVI) ....160

### Owner Checks and Services

Owner Checks and Services .....162

### Recommended Fluids, Lubricants, and Parts

Recommended Fluids and Lubricants .....163

## General Information

### Maintenance

Proper vehicle maintenance will not only keep your vehicle in good working condition but also be beneficial to environmental protection. To protect the environment and maintain good condition, perform vehicle maintenance correctly.

All matters stipulated in this system apply to vehicles in the warranty period and are only for recommendation or reference for vehicles out of the warranty period.

1. The maintenance service provided should be done by your dealer. After the maintenance is completed, your dealer should fill in the "Maintenance Record Form", and the you should sign it after confirmation.
2. The quality problems found during maintenance should be handled according to the provisions of the warranty service.
3. The Maintenance Specification Table stipulates the time and mileage for each maintenance service. The maintenance must be maintained at the dealer within the warranty period according to the time limit

specified in the Maintenance Specification Table. After the maximum warranty period, it is suggested to see your dealer for appropriate maintenance according to the time and mileage interval specified in the Maintenance Specification Table, or in advance as appropriate.

## Maintenance Schedule

### Tire Rotation and Required services Every 12 000 km (7,500 mi) or Every 12 months – Whichever Comes First

Tires are rotated to achieve a more uniform wear for all tires. The first rotation is the most important.

Anytime unusual wear is noticed, rotate the tires as soon as possible, check for proper tire inflation pressure, and check for damaged tires or wheels. If the unusual wear continues after the rotation, check the wheel alignment.

- Perform Multi-Point Vehicle Inspection. See *Multi-Point Vehicle Inspection (MPVI)* ⇨ 160.
- Lubricate body components. See *Exterior Care* ⇨ 156.



## Required Services

**First service at 6 000 km (3,750 mi) or six months. Subsequent services must occur every 12 000 km (7,500 mi) or 12 months, whichever comes first.**

- Change the engine oil and filter. Use Dexos 1 Gen 3.

Under severe conditions\*, replace the engine oil and filter every 6 000 km or six months, whichever comes first. See *Engine Oil* ⇨ 131 for additional details.

**First service at 6 000 km (3,750 mi) and subsequent services every 24 000 km (15,000 mi).**

- Replace Manual Transmission oil (if equipped).

**Every 12 000 km (7,500 mi)**

- Replace the engine air filter. See *Engine Air Cleaner/Filter* ⇨ 133.

**First service at 12 000 km (7,500 mi) and subsequent services every 24 000 km (15,000 mi)**

- Replace the spark plugs.

**Every 60 000 km (37,000 mi)**

- Replace CVT transmission fluid (if equipped).

**Every 240 000 km (150,000 mi)**

- Drain and fill engine cooling system. Or every six years, whichever comes first. See *Engine Coolant* ⇨ 133. Replace with a 50/50 mixture of clean drinkable water and DEX-COOL coolant, according with program maintenance. When necessary, Refill ONLY 50/50 mixture of clean drinkable water and DEX-COOL. Failure to use the recommended coolant can result in damage to the engine cooling system and vehicle, which would not be covered by the vehicle warranty.

## Owner Checks and Services

**Every Three Years**

- Replace brake fluid. Use DOT 4.

### \*Severe Conditions Requiring More Frequent Maintenance

- You drive your vehicle 10 km or less; engine is working idle more than 30% of the total time of your trip.

- Off road and irregular road conditions or under extreme climatological conditions (high pollution, sand, mud, difference in altitudes).
- When you cold-start your vehicle, drive and having continuous stops (public, services, military or commercial taxis, ambulances, police cars and emergency rescue vehicles, civilian vehicles such as light duty pick-up trucks, SUVs and passenger cars that are used in military applications, high-use commercial vehicles such as courier delivery vehicles, private security patrol vehicles or any vehicles that operate on a 24-hour basis, etc.).
- When the vehicle is driven at extreme temperatures of below 0 °C or above 35 °C.
- When vehicle is driven on continuous high speeds (80% or more of maximum vehicle speed) for over 2 hours.

## Multi-Point Vehicle Inspection (MPVI)

A Multi Point Vehicle Inspection (MPVI) completed by a GM dealer technician is a maintenance assessment of your vehicle. The benefit of the MPVI is to identify and

inform the customer of service items that require immediate attention and those that may require attention in the future.

The technician will perform the following checks on your vehicle. For a complete list of checks, inspections, and services, see your dealer.

Some items may not apply to your vehicle and/or region.

### **Diagnostics**

- OnStar active, if equipped
- Service history/recall check

### **Engine Oil and Filter**

- Engine oil
- Oil life monitor
  - Reset oil life monitor

### **Exterior Lights**

- Visual inspection

### **Windshield and Wipers**

- Visual inspection

### **Battery**

- Battery visual inspection
- Battery test results
- Battery cables and connections

### **Systems, Fluids, and Visible Leak Inspection**

- Engine oil
- Transmission
- Drive axle
- Transfer case
- Engine cooling system
- Power steering, if equipped
- Fuel system
- Windshield washer fluid

### **Tire Inspection**

- Tire pressure, tread depth, and wear
- Rotation, if applicable
- Alignment check, optional
- Reset tire pressure monitor
- Check tire sealant expiration date, if equipped

- Check spare tire, if equipped

### **Brakes**

- Check brake system

### **Visible and Functional Inspections**

- Seat belt components
- Exhaust system
- Accelerator pedal
- Passenger compartment air filter, if equipped
- Engine air filter
- Hoses
- Belts
- Shocks and struts
- Steering components
- Axle boots or driveshaft and u-joints
- Compartment lift struts, if equipped
- Floor mats secured, no interference with pedals
- Horn
- Ignition lock, if equipped
- Starter switch

- Evaporative control system

### Lubricate

- Chassis components

## Owner Checks and Services

Check the interior, exterior and engine compartment regularly to keep the vehicle safe and reliable.

### Exterior

#### Tire

- Inflate tires correctly. See *Wheels and Tires*  
⇨ 145
- There is no crack on tire wall or tire tread.
- There is no foreign matter in tread pattern.

#### Lamp

- It includes all driving lamps, head lamps, tail lamps, turn signal lamps, brake lamps and fog lamps.

#### Oil Tank

- Check whether the level of fluid containers under engine hood is appropriate.

### Windshield Wiper

- Check the state of wiper arms and blades.

### Interior

#### Steering

- Check whether the steering wheel is too loose (free travel).

#### Parking Brake

- Ensure the travel of parking brake lever is appropriate.

#### Instrument panel

- Check whether all instruments, control buttons and warning lamps are functioning normally.

#### Rearview Mirror

- Ensure the reflecting surface of rearview mirror is in good state and clean.
- Check whether all rearview mirrors can be readjusted.

#### Control

- Check the brake pedal and clutch pedal for appropriate travel.

## Recommended Fluids, Lubricants, and Parts

### Recommended Fluids and Lubricants

Name	Trade Mark	Capacity (L)	
		LZW7156CJYD	LZW7156EJY
Motor Gasoline	RON 92 and above motor gasoline	45	45
Engine Lubricating Oil <sup>1</sup>	Dexos 1 Gen 3, 5W-30	3.5	3.5
Manual Transmission Oil	SAE 75W/90 or 75W/80	1.8	—
Coolant	DEX-COOL with mixture of 50/50	6.5-7.0	6.5-7.0
Brake Fluid (including Hydraulic Clutch Fluid)	DOT4	0.55	0.55
A/C Refrigerant	HFC-134a	510±20g	510±20g
CVT Oil <sup>1</sup>	Shell SL2100	—	4L (service replacement) / 7.5L (total volume)

<sup>1</sup>All capacities are approximate. When adding, be sure to fill to the approximate level, as recommended in this manual. Recheck fluid level after filling.

## Technical Data

### Vehicle Identification

Vehicle Identification Number (VIN) ..... 164

Engine Identification ..... 165

### Vehicle Data

Vehicle Data ..... 166

Engine Drive Belt Routing ..... 172

## Vehicle Identification

### Vehicle Identification Number (VIN)

There are four commonly used VIN marks on the vehicle.

#### VIN on Instrument Panel

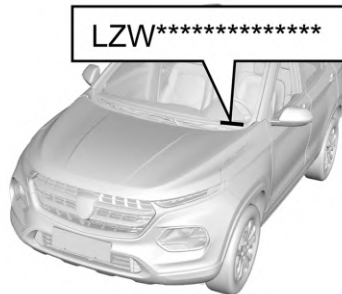

It is the legal identification mark of the vehicle. The VIN is at the front corner of instrument panel at the driver's side. It can be seen from the outside via the front windshield.

#### VIN Rubbing Seal under Engine Hood

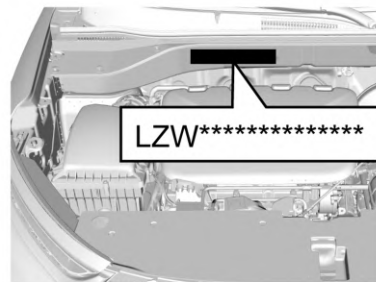

It is located under the engine hood below the wiper.

### Vehicle Identification Plate

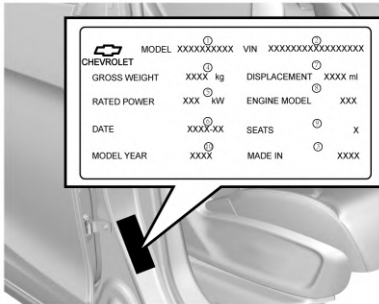

This plate is located on the front side door frame.

### VIN Label under Liftgate

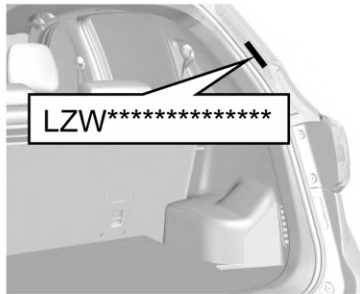

Open the liftgate, and it can be seen that the label is below the liftgate strut support on the right side.

### Engine Identification

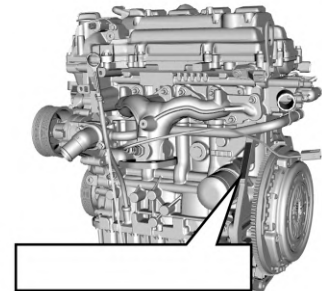

Located on the engine cylinder block near the flywheel.

## Vehicle Data

### Main Engine Performance Parameters

Item	Unit	Parameter Engine Model: L2B LZW7156CJYD	Parameter Engine Model: L2B LZW7156EJY	Parameter Engine Model: LAR LZW7156CJYD	Parameter Engine Model: LAR LZW7156EJY
		Transmission model: F616A, F616A1	Transmission model: CTF25D	Transmission model: F616A, F616A1	Transmission model: CTF25D
Engine Type	—	Four-stroke, water-cooled, in-line, 16-valve, dual overhead camshaft, timing chain drive, naturally aspirated, electronically controlled gasoline injection and electronically controlled ignition with DVCP (double variable cam phase)	Four-stroke, water-cooled, in-line, 16-valve, dual overhead camshaft, timing chain drive, naturally aspirated, electronically controlled gasoline injection and electronically controlled ignition with DVCP (double variable cam phase)	Four-stroke, water-cooled, in-line, 16-valve, dual overhead camshaft, timing chain drive, naturally aspirated, electronically controlled gasoline injection and electronically controlled ignition with DVCP (double variable cam phase)	Four-stroke, water-cooled, in-line, 16-valve, dual overhead camshaft, timing chain drive, naturally aspirated, electronically controlled gasoline injection and electronically controlled ignition with DVCP (double variable cam phase)
Cylinder Diameter × Travel	mmxmm	74.7 x 84.7	74.7 x 84.7	74.7 x 84.7	74.7 x 84.7

Item	Unit	Parameter Engine Model: L2B LZW7156CJYD	Parameter Engine Model: L2B LZW7156EJY	Parameter Engine Model: LAR LZW7156CJYD	Parameter Engine Model: LAR LZW7156EJY
Displacement	L	1.485	1.485	1.485	1.485
Compression Ratio	—	10.2:1	10.2:1	10.2:1	10.2:1
Rated Power/ Speed	kW/(r/min)	82/5800	82/5800	73/5800	73/5800
Maximum Net Power/Speed	kW/(rpm)	78/5800	78/5800	70/5800	70/5800
Maximum Torque/Speed	Nm/(rpm)	146.5/(3600–4000)	146.5/(3600–4000)	143/(3400-4400)	143/(3400-4400)
Gross Mass	kg	111.5±2	106.5±2	112±2	101.5±2
Idle Speed	rpm	750±50	750±50	750±50	750±50
Fuel type and grade	—	RON 92 and above motor gasoline	RON 92 and above motor gasoline	RON 92 and above motor gasoline	RON 92 and above motor gasoline



Item	Unit	Parameter Engine Model: L2B LZW7156CJYD	Parameter Engine Model: L2B LZW7156EJY	Parameter Engine Model: LAR LZW7156CJYD	Parameter Engine Model: LAR LZW7156EJY
Engine Layout and Driving Type	—	Front Wheel Drive, Forward	Front Wheel Drive, Forward	Front Wheel Drive, Forward	Front Wheel Drive, Forward
Whole Vehicle Emission Standard	—	Euro 5	Euro 5	Euro 5	Euro 5

**Main Quality Parameters of Complete Vehicle**

Items	Parameter LZW7156CJYD	Parameter LZW7156EJY
Seats	5 person	5 person
Curb weight	1206 kg 1218 kg 1260 kg	1260 kg 1290 kg
Front axle load of curb weight	723 kg 725 kg 740 kg	770 kg 775 kg
Rear axle load of curb weight	483 kg 493 kg 520 kg	490 kg 515 kg
Total mass	1635 kg	1670 kg
Front axle load	840 kg	870 kg
Rear axle load	795 kg	800 kg

### Main Technical Parameters of Complete Vehicle

Items	Parameters LZW7156CJYD	Parameters LZW7156EJY
Total length	4220 mm	4220 mm
Total width	1740 mm	1740 mm
Total height (no load)	1615 mm 1625 mm	1615 mm 1625 mm
Wheel base	2550 mm	2550 mm
Front suspension	845 mm	845 mm
Rear suspension	825 mm	825 mm
Front wheel track	1490 mm	1490 mm
Rear wheel track	1496 mm	1496 mm
Approach angle (no load/full load)	22°/19°	22°/19°
Departure angle (no load/full load)	28°/23°	28°/23°
Minimum ground clearance (full load)	160 mm	160 mm
Minimum turning diameter	10.7 m	10.7 m

### Name and Position of Parts not Included in Vehicle Overall Dimensions as Required by GB1589

Name	Position
Wiper and washer	Vehicle rear end
Exterior identifications, including the product trademark, company name identification and other identifications that reflect vehicle characteristics	Vehicle front end, rear end and vehicle side
Lighting and optical signal device	Vehicle front end, rear end and vehicle side
Rear identification plate (with LOGO)	Vehicle rear end
Detachable vehicle hooking or dragging device	Vehicle front end and rear end
Exhaust tail pipe	Vehicle rear end
Indirect vision device	Vehicle front end, rear end and vehicle side
Anti-collision rubber block and similar devices	Vehicle side
Flexible protrusion of spray-suppression system	Vehicle side
Handle and switch	Vehicle side
Deformed portion of the tire wall right above the tire contact point	Tire side
Soft part of the antenna	Roof

Note: Refer to the national standard GB1589 for details of the unlisted parts.

## Power Performance Parameters

Item	Parameter LZW7156CJYD	Parameter LZW7156EJY	Testing Method
Maximum vehicle speed	≥160 km/h	≥160 km/h	GB/T 12544-2012 Km/h
Maximum climbing gradient	≥30%	≥30%	GB/T 12539-2018

## Engine Drive Belt Routing

For normal operation of engine and air compressor, the drive belt should be adjusted to a good state. In case of damage, break or wear, please replace the drive belt.

## Caution

Never leave the key in the ignition while checking the drive belts. The engine could start unexpectedly. Moving engine parts can cause serious personal injury.

## Customer Information

### Customer Information

Customer Satisfaction Procedure .....	173
Customer Assistance Offices .....	174
Online Owner Center .....	174
Roadside Assistance Program .....	175
Radio Frequency Statement .....	177

### Reporting Safety Defects

Reporting Safety Defects to General Motors .....	177
--	-----

## Customer Information

### Customer Satisfaction Procedure

#### Extended Warranty



Did you get the Warranty Extension Plan? This plan is recommended by General Motors to supplement the warranty included with the new vehicle purchase.

See your dealer for details.

#### Customer Assistance Procedure

Owner satisfaction and goodwill are very important to your dealer and General Motors.

Normally, any problem with the transaction, sale, or usage of the vehicle must be handled by your dealer sales or service departments. However, we recognize that despite the good intentions of all parties involved, sometimes a misunderstanding may occur.

If you have a problem that has not been satisfactorily handled through the normal means, we suggest the following steps:

#### STEP ONE

Explain your case to your dealer service agent, service manager, dealer sales agent, or sales manager, depending on your case.

Make sure that they have all necessary information. They are interested in your continual satisfaction.

#### STEP TWO

If you are not satisfied, please contact the general manager or your dealership owner to ask for their help. If they are not able to resolve your case, ask them to contact the right people at General Motors for support, if needed.

**STEP THREE**

If your case is not resolved in a reasonable amount of time by your dealer, please call the General Motors Customer Assistance Center (CAC) and provide the following information:

- Name
- Address
- Phone number
- Model year
- Brand
- Vehicle Identification Number (VIN)
- Mileage
- Delivery date
- Description of the problem
- Dealership name
- Dealership address

See *Customer Assistance Offices* ⇨ 174.

**Customer Assistance Offices**

To contact the Customer Assistance Center (CAC), use the phone numbers listed in this section. Customer assistance is available Monday through Friday, 08:00 to 20:00 hours, and Saturdays from 09:00 to 15:00 hours.

All e-mail inquiries to the Customer Assistance Center (CAC) should be sent to: [asistencia.gmmexico@gm.com](mailto:asistencia.gmmexico@gm.com).

For assistance in English:  
[mx\\_gm\\_customerassistance@gm.com](mailto:mx_gm_customerassistance@gm.com).

**Mexico**

800-466-0811

800-508-0000

**United States**

1-800-222-1020

**Canada**

1-800-268-6800

**Nicaragua**

00-1800-226-0510

**Other Central American and Caribbean Countries**

52-555-901-2369

**Online Owner Center****Online Owner Experience [my.chevrolet.com.mx](http://my.chevrolet.com.mx)**

The Owner Center is not available for any of the countries in the Central American and Caribbean region.

The Chevrolet online owner experience allows interaction with Chevrolet and keeps important vehicle-specific information in one place.

**Membership Benefits**

 : Download owner's manuals and view vehicle-specific how-to videos.

 : View maintenance schedules, alerts, and Vehicle Diagnostic Information. Schedule service appointments.

 : View and print self-recorded service records.

 : Select a preferred dealer and view locations, maps, phone numbers, and hours.

: Track your vehicle's warranty information.

: View active recalls by Vehicle Identification Number (VIN). See *Vehicle Identification Number (VIN)* ⇨ 164.

: View OnStar account information (if equipped).

: Chat with online help representatives.

**Store**: Buy online OnStar packages, Connected Services, and Data.

See [my.chevrolet.com.mx](http://my.chevrolet.com.mx) to register your vehicle.

## Roadside Assistance Program

The Roadside Assistance program is not available for any of the countries in the Central American and Caribbean region.

As a new owner, your vehicle is automatically enrolled in the Roadside Assistance program. The services are available at no cost under the terms and conditions of the program. The Roadside Assistance program is not part of, or included, in the coverage provided by the New Vehicle Limited Warranty.

Roadside Assistance provides assistance to the driver and passengers while driving the vehicle within your city of residence or on any

passable road in Mexico, the United States, and Canada. Services are subject to the limitations described in the following pages. Program coverage varies by country.

Roadside Assistance is available 24 hours a day, 365 days of the year.

This program expires three years from the date of sale of the vehicle, regardless of vehicle mileage and changes in vehicle ownership.

For more information about the renewal of this program at the end of its term, contact the Chevrolet Customer Assistance Center at 800-466-0811 or 800-508-0000.

### Services Provided

- **Flat Tire Change**: If unable to change a flat tire, Roadside Assistance will provide towing service to the nearest authorized Chevrolet dealership. It is the owner's responsibility for the repair or replacement of the tire. This service is limited to the transfer of the vehicle to the repair facility.
- **Emergency Fuel Delivery**: Delivery of enough fuel for the vehicle to get to the nearest service station.

- **Lock-Out Service**: Service to unlock the vehicle if you are locked out. A remote unlock may be available if the vehicle has OnStar. For security reasons, the driver must present identification before this service is provided.
- **Battery Jump Start**: Service to jump start a dead battery.
- **\*Emergency Messages**: Transmission of urgent phone messages.
- **\*Emergency Calls**: Call for emergency services.
- **\*Dealership Location Assistance**: Information regarding addresses and telephone numbers for Chevrolet dealers.
- **Emergency Towing**: Tow to the nearest dealer for warranty service if the vehicle cannot be driven.  
  
If the vehicle is involved in a crash during the commission of a crime, administrative violation, or breach of traffic regulations, Roadside Assistance will not provide service. When the vehicle is not accessible to be towed, all maneuvers required to access it will be at the owner's expense.



If the vehicle is in another city outside of your residence, Roadside Assistance is limited to moving the vehicle to the nearest dealer. If you would like the vehicle moved to a different dealer, you will be asked to cover the difference in cost at the time of the move.

If the vehicle cannot be received by the nearest Chevrolet dealer due to scheduling conflicts, the vehicle will be taken to a safe place where it will remain for up to 48 hours until it can be taken to the dealer. If the storage costs exceed the amount authorized, the owner is responsible to pay the difference at the time of service. Contact Roadside Assistance for more information on authorized amounts.

- **\*Trip Interruption:** This service is provided if you are prevented from further usage of your vehicle while traveling and it is not possible for the nearest Chevrolet dealership to repair the vehicle the same day, requiring the vehicle to stay at the dealership for a night or more. If this happens, in addition to the previously listed services and prior to confirmation by the dealership, you are entitled to choose one of the following alternatives, within

the limits of existing Roadside Assistance program guidelines. If the costs exceed the amount authorized for these services, you must pay the difference at the time of service.

Roadside Assistance will coordinate hotel accommodations for all vehicle travelers for up to two nights.

A rental car will be provided for up to two days and the vehicle must be returned to its original destination, excluding vehicles with a carrying capacity greater than 3.5 tons.

**Complimentary Transportation:** If you prefer to continue your trip to the intended destination or return to your place of residence, and the trip requires more than eight hours driving on the road, transportation for the driver and passengers by first class bus or coach commercial airline will be provided to a location chosen by Roadside Assistance, depending on availability at the chosen destination. Restrictions apply based on vehicle specifications.

If you are on the road, taxi service to the nearest bus station or airport will be provided.

- **\*Complimentary Transportation for Vehicle Pick Up:** Transportation to pick up your vehicle after repairs are complete. Once the dealer has reported that the vehicle has been repaired, Roadside Assistance will provide bus or commercial airline one-way service (subject to availability) for the person designated by you to collect your vehicle at the dealership's location if you or the designated person are not in the same town or city as the dealership.

\*These services are not provided for U.S. or Canada residents. All services provided in the U.S. and Canada are at the owner's expense and will be reimbursed by Roadside Assistance.

#### **Services Not Included in Roadside Assistance**

Roadside Assistance does not cover or reimburse services for the following:

- Events caused by fraud or bad faith by the driver.
- Vehicle immobilization situations due to a major force or unforeseen circumstances, such as natural phenomena of an extraordinary nature, earthquakes, volcanic eruptions, and other cyclonic storms.

- Vehicle immobilization situations arising from car crashes caused by the driver of the vehicle or third parties. This means any occurrence that causes physical injury to the occupants and/or the vehicle caused by external forces.
- Acts of terrorism, riot or uproar, armed forces or police actions which prevent timely delivery of assistance services.
- Food service, beverages, telephone calls, or other extra costs. Accommodation costs apply only to Mexico per the terms and conditions of the Roadside Assistance program.
- Any damage to the vehicle without intent, derived from the services provided.
- Cost of towing a trailer when choosing a Chevrolet dealer that is nearest to the temporary storage facility for the disabled vehicle.
- Cost of all maneuvers required to access the vehicle when it is not available to be towed.
- Cost of fuel provided.

Routine vehicle repair costs are not covered by the Roadside Assistance program. For more information, see your new vehicle warranty.

### Contacting Roadside Assistance

Roadside Assistance services are of no cost to you and available 24 hours a day, 365 days a year. Costs are only incurred in situations that exceed the limits of the program, some of which are listed previously in this section.

To contact Roadside Assistance by phone, use the following numbers:

#### Mexico

800-466-0811

800-508-0000

#### United States

1-800-222-1020

#### Canada

1-800-268-6800

#### E-mail

asistencia.gmmexico@gm.com

For assistance in English:

mx\_gm\_customerassistance@gm.com

*Chevrolet reserves the right to make any changes or discontinue the Roadside Assistance program at any time without notification.*

### Radio Frequency Statement

This vehicle has systems that operate on a radio frequency that complies with NOM-EM-016-SCFI-2015 or NOM-208-SCFI-2016 and National Radio Frequency Allocation Chart.

Operation of this equipment is subject to the following two conditions:

1. This equipment or device may not cause harmful interference.
2. This equipment or device must accept any interference received, including interference that may cause undesired operation.

### Reporting Safety Defects

#### Reporting Safety Defects to General Motors

In addition to notifying NHTSA (or Transport Canada) in a situation like this, notify General Motors.

In the U.S., call 1-800-222-1020, or write:

Chevrolet Motor Division  
Chevrolet Customer Assistance Center  
P.O. Box 33170  
Detroit, MI 48232-5170

In Canada, call 1-800-263-3777 (English) or 1-800-263-7854 (French), or write:

General Motors of Canada Company  
Customer Care Centre, Mail Code: CA1-163-005  
1908 Colonel Sam Drive  
Oshawa, Ontario L1H 8P7

In Mexico, call 800-466-0811 or 800-508-0000.

In other Central America and Caribbean Countries, call 52-555-901-2369.

## Index

<b>A</b>	
Accessories and Modifications.....	128
Adjustments	
Seat, Initial Drive.....	21
Air	
Cleaner/Filter, Engine.....	133
Conditioning.....	101
Vents.....	104
Airbags	
Readiness Light.....	59
Airbag System.....	27
How Does an Airbag Restrain?.....	29
What Makes an Airbag Inflate?.....	29
What Will You See after an Airbag Inflates?.....	30
When Should an Airbag Inflate?.....	29
Where Are the Airbags?.....	28
Air Conditioning.....	87
AM-FM Radio.....	81
Antilock Brake System (ABS).....	118
Warning Light.....	62
Appearance Care	
Exterior.....	156
Interior.....	157
Apple CarPlay and Android Auto.....	83
Ashtrays.....	53
Assistance Program, Roadside.....	175

Assistance Systems	
Parking and Backing.....	123
Audio	
Bluetooth.....	82

**B**

Battery	
Jump Starting.....	152
Blade Replacement, Wiper.....	136
Bluetooth	
Audio.....	82
Overview.....	82
Brake	
Fluid.....	135
System Warning Light.....	61
Brakes.....	117, 135
Antilock.....	118
Electric Parking Brake.....	120
Parking Brake.....	119
Break-In, New Vehicle.....	111
Bulb Replacement.....	137

**C**

Carbon Monoxide	
Liftgate.....	12
Caution, Danger, and Warning.....	1
Central Locking System.....	11
Chains, Tire.....	148

- |   |         |                                      |     |  |     |
|---|---------|--------------------------------------|-----|--|-----|
| Charging                                    |         | Cupholders.....                      | 42  | Electronic                               |     |
| System Light.....                           | 60      | Customer Assistance                  |     | Stability Control (ESC).....             | 121 |
| Check Engine Light (Malfunction             |         | Offices.....                         | 174 | Emergencies.....                         | 110 |
| Indicator).....                             | 60      | Customer Satisfaction Procedure..... | 173 | Engine                                   |     |
| Child Restraint Installation Locations..... | 37      |                                      |     | Air Cleaner/Filter.....                  | 133 |
| Child Restraints                            |         | <b>D</b>                             |     | Check Light (Malfunction Indicator)..... | 60  |
| Infants and Young Children.....             | 34      | Danger, Warning, and Caution.....    | 1   | Compartment Overview.....                | 130 |
| Installation Locations.....                 | 37      | Daytime Running Lamps (DRL).....     | 74  | Coolant.....                             | 133 |
| ISOFIX.....                                 | 38      | Devices                              |     | Coolant Temperature Gauge.....           | 57  |
| Cleaning                                    |         | USB.....                             | 81  | Coolant Temperature Warning Light.....   | 64  |
| Exterior Care.....                          | 156     | Door                                 |     | Drive Belt Routing.....                  | 172 |
| Interior Care.....                          | 157     | Ajjar Light.....                     | 68  | Oil Pressure Light.....                  | 65  |
| Climate Control Systems.....                | 87, 101 | Central Locking System.....          | 11  | Starter Protection.....                  | 114 |
| Air Conditioning.....                       | 87      | Locks.....                           | 8   | Starting.....                            | 114 |
| Heating.....                                | 87      | Drive Belt Routing, Engine.....      | 172 | Engine Identification.....               | 165 |
| Clock.....                                  | 52      | Driver                               |     | Exterior                                 |     |
| Cluster, Instrument.....                    | 54      | Information Center (DIC).....        | 69  | Lamp Controls.....                       | 73  |
| Compartment                                 |         | Driving                              |     |  |     |
| Luggage.....                                | 44      | Emergencies.....                     | 110 | <b>F</b>                                 |     |
| Continuously Variable Transmission          |         | Off-Road.....                        | 109 | Filter                                   |     |
| (CVT).....                                  | 116     | Driving Lamps.....                   | 75  | Engine Air Cleaner.....                  | 133 |
| Control of a Vehicle.....                   | 108     |                                      |     | Flashers, Hazard Warning.....            | 74  |
| Coolant                                     |         | <b>E</b>                             |     | Flat Tire                                |     |
| Engine.....                                 | 133     | Electric                             |     | Changing.....                            | 149 |
| Engine Temperature Gauge.....               | 57      | Parking Brake.....                   | 120 | Floor Console                            |     |
| Engine Temperature Warning Light.....       | 64      | Electrical System                    |     | Storage.....                             | 43  |
| Cooling.....                                | 87, 101 | Engine Compartment Fuse Block.....   | 143 | Fluid                                    |     |
| Cruise Control.....                         | 122     | Fuses.....                           | 142 | Brakes.....                              | 135 |
| Light.....                                  | 68      |                                      |     |  |     |

Transmission Life System.....	133
Washer.....	134
Fog Lamp Light	
Rear.....	67
Fog Lamps	
Rear.....	75
Frequency Statement	
Radio.....	177
Front	
Storage.....	42
Front Seat Position Seats	
Adjustment.....	21
Front Seats	
Adjustment.....	21
Fuel	
Recommended.....	125
Filling the Tank.....	126
Gauge.....	57
Low Fuel Warning Light.....	66
Fuses.....	142
Engine Compartment Fuse Block.....	143

## G

Gauges	
Engine Coolant Temperature.....	57
Fuel.....	57
Odometer.....	56
Speedometer.....	55

Tachometer.....	56
Turn Signal.....	57
Glove Box.....	42

## H

Hazard Warning Flashers.....	74
Headlamps	
Bulb Replacement.....	137
Daytime Running Lamps (DRL).....	74
High-Beam On Light.....	67
Lamps On Reminder.....	67
Head Restraints.....	20
Heating.....	87
High-Beam On Light.....	67
Hill Start Assist (HSA).....	120
Hood.....	11
Hooks	
Shopping Bag.....	45
Horn.....	50
HVAC.....	87, 101

## I

Ignition Positions.....	112, 113
Infants and Young Children, Restraints.....	34
Information on Loading the Vehicle.....	46
Inspection	
Multi-Point Vehicle.....	160
Instrument Cluster.....	54

Instrument Panel	
Storage Area.....	41
Instrument Panel Overview.....	48
Interior	
Rearview Mirrors.....	14
Introduction.....	1
ISOFIX Child Restraint Systems.....	38

## J

Jump	
Starting.....	152

## K

Keyless Entry	
Remote (RKE) System Operation.....	4
Keys.....	3

## L

Lamps	
Daytime Running (DRL).....	74
Driving.....	75
Exterior Controls.....	73
Load Compartment.....	75
Malfunction Indicator (Check Engine).....	60
On Reminder.....	67
Reading.....	76
Rear Fog.....	75
Lap-Shoulder Belt.....	25
Liftgate.....	12

## Lights

Airbag Readiness.....	59
Antilock Brake System (ABS) Warning....	62
Brake System Warning.....	61
Charging System.....	60
Check Engine (Malfunction Indicator)....	60
Cruise Control Light.....	68
Door Ajar.....	68
Engine Coolant Temperature Warning.....	64
Engine Oil Pressure.....	65
High-Beam On.....	67
Low Fuel Warning.....	66
Rear Fog Lamp.....	67
Seat Belt Reminders.....	58
Security.....	66
StabiliTrak OFF.....	63
Tire Pressure.....	65
Traction Control System (TCS)/ StabiliTrak.....	64
Warning, Power Steering.....	63
Load	
Compartment Lamps.....	75
Loading the Vehicle.....	46
Locks	
Central Locking System.....	11
Door.....	8
Low Fuel Warning Light.....	66
Luggage Compartment.....	44

## M

Maintenance.....	159
Maintenance Schedule.....	159
Recommended Fluids and Lubricants.....	163
Malfunction Indicator Lamp.....	60
Manual	
Transmission.....	116
Mirrors	
Interior Rearview.....	14
Power.....	13
Multi-Point Vehicle Inspection (MPVI).....	160

## N

New Vehicle Break-In.....	111
---------------------------	-----

## O

Odometer.....	56
Off-Road	
Driving.....	109
Oil	
Engine.....	131
Pressure Light.....	65
Online Owner Center.....	174
Other Service Items	
Air Conditioning System.....	101
Outlets	
Power.....	52

Overview.....	78
Instrument Panel.....	48
Owner Checks and Services.....	162

## P

Pairing a Phone Using the Infotainment System.....	83
Park	
Assist.....	123
Parking.....	116
Brake.....	119
Parking or Backing	
Assistance Systems.....	123
Phone	
Apple CarPlay and Android Auto.....	83
Bluetooth.....	82
Power	
Mirrors.....	13
Outlets.....	52
Steering Warning Lights.....	63
Windows.....	15
Pregnancy, Using Seat Belts.....	26

## R

Radio	
AM-FM Radio.....	81
Frequency Statement.....	177
Reading Lamps.....	76

Rear	
Fog Lamps.....	75
Seats.....	23
Storage.....	43
Window Washer/Wiper.....	51
Recommended	
Fuel.....	125
Recommended Fluids and Lubricants.....	163
Remote	
Keyless Entry (RKE) System Operation.....	4
Repair Kit	
Tire.....	148
Reporting Safety Defects	
General Motors.....	177
Ride Control Systems	
Electronic Stability Control (ESC).....	121
Roadside Assistance Program.....	175
Roof	
Rack System.....	45
Sunroof.....	16
Rotation, Tires.....	148
Routing, Engine Drive Belt.....	172

## S

Safety Defects Reporting	
General Motors.....	177
Seat Belts.....	24
Child Restraints.....	37
Lap-Shoulder Belt.....	25

Reminders.....	58
Use During Pregnancy.....	26
Seats	
Adjustment, Front.....	21
Head Restraints.....	20
Position, Front.....	21
Rear.....	23
Security	
Light.....	66
Service	
Accessories and Modifications.....	128
Climate Control System.....	87
Settings.....	84
Shopping Bag Hooks.....	45
Signals, Turn and Lane-Change.....	75
Speedometer.....	55
StabiliTrak	
OFF Light.....	63
Start Assist, Hill.....	120
Starter Protection, Engine.....	114
Starting the Engine.....	114
Steering.....	108
Power, Warning Lights.....	63
Wheel Adjustment.....	49
Wheel Controls.....	49
Stop/Start System.....	115
Storage	
Cupholders.....	42
Floor Console.....	43

Front.....	42
Glove Box.....	42
Information on Loading the Vehicle.....	46
Instrument Panel Areas.....	41
Luggage Compartment.....	44
Rear.....	43
Roof Rack System.....	45
Vehicle.....	129
Sunroof.....	16
Sun Visors.....	16
System	
Airbag.....	27
Roof Rack.....	45

## T

Tachometer.....	56
Time.....	52
Tire Repair Kit.....	148
Tires	
Chains.....	148
Changing.....	149
Pressure.....	146
Pressure Light.....	65
Rotation.....	148
Winter.....	146
Tires and Wheels.....	145
Tools.....	145
Towing	
Vehicle.....	154



Traction	
Control System (TCS)/StabiliTrak Light.....	64
Transmission	
Continuously Variable.....	116
Fluid Life System.....	133
Manual.....	116
Tread Depth.....	147
Turn and Lane-Change Signals.....	75
Turn Signal.....	57

## U

USB.....	81
Using	
Pairing a Phone, Infotainment System.....	83
This Manual.....	1

## V

Vehicle	
Control.....	108
Data.....	166
Identification Number (VIN).....	164
Storage.....	129
Towing.....	154
Vehicle Care	
Tire Pressure.....	146
Ventilation, Air.....	104
Visors.....	16

## W

Warning	
Brake System Light.....	61
Caution and Danger.....	1
Hazard Flashers.....	74
Washer Fluid.....	134
Wheels and Tires.....	145
Windows	
Power.....	15
Windshield	
Wiper/Washer.....	50
Winter	
Tires.....	146
Wiper	
Blade Replacement.....	136
Rear Washer.....	51



PART NUMBER. 85095387 A

